

UNIVERSAL TURNING NEW DEFINED

CLX 450 TC

CLX TC



NEW

CLIMATE-NEUTRAL PRODUCTION
OF OUR MACHINES



Machine and technology

Machine configurator

Control and technology cycles

Applications

Floor plans/Working space/Technical data

CLX TC

The beginning of a new era

Universal turning new defined



02

CLX TC – Tool carrier 2.0

- + Automatic tool change with 30 or 60 tools for maximum flexibility
- + Short setup and non-productive times, thanks to tool setup parallel to production time
- + Excentric turning and milling with the Y axis as standard
- + No angle tools required thanks to B-axis with 0.001° resolution in standard
- + Maximum usability of the working space with compactMASTER spindle
- + Highest safety – No unused tools in the work area and expandable with Machine Protection Control

The manufacturing of the future

High flexibility – low set-up times

+ **Falling batch sizes and increasing cost pressure** – these are the challenges facing many companies today. With the new CLX 450 TC, you can easily master these challenges – and at an unbeatable price.

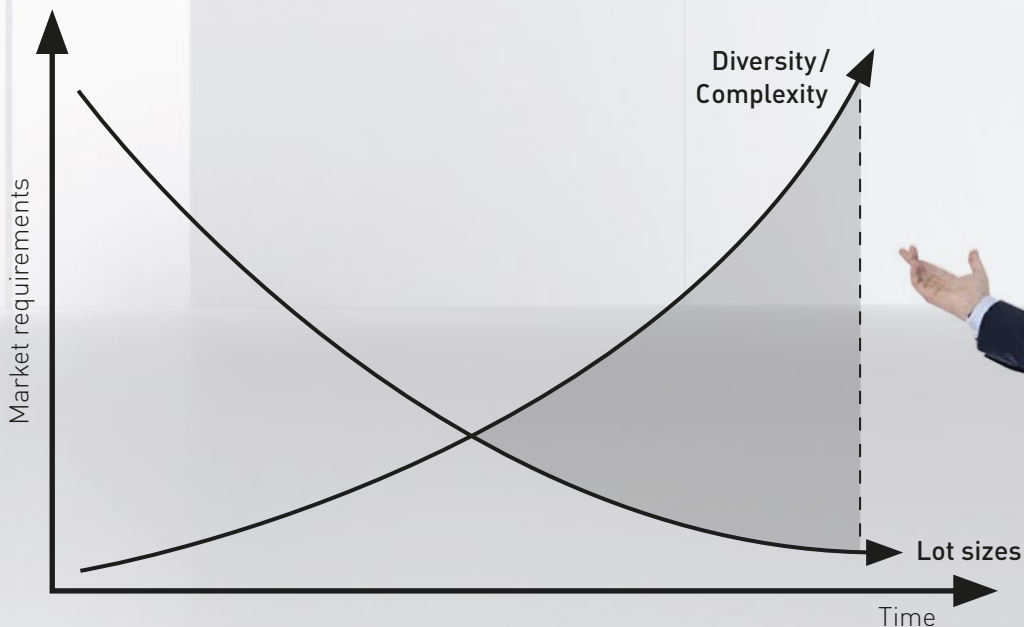

The new universal turning machine from DMG MORI offers you:

- + Full flexibility through perfect combination of turning and milling machine
- + Increased productivity by means of high machine availability and simple automation capability
- + High repeatability, thanks to a robust machine concept
- + Simple, intuitive operation and dialog-guided technology cycles
- + Easy planning of production due to complete machining of jobs
- + Short delivery times of standard machines
- + Fast service times thanks to global service presence and expert staff



Machine and technology

Machine configurator

Control and technology cycles

Applications

Floor plans/Working space/Technical data

CLX TC

The B-axis factor

Added value compared to any turret lathe

- + Highest flexibility in machining with 30 or 60-station tool magazine
- + Short set-up and non-productive times, thanks to automatic and fast tool changing



No need for costly angle tools thanks to the B-axis with 0,001° resolution as standard

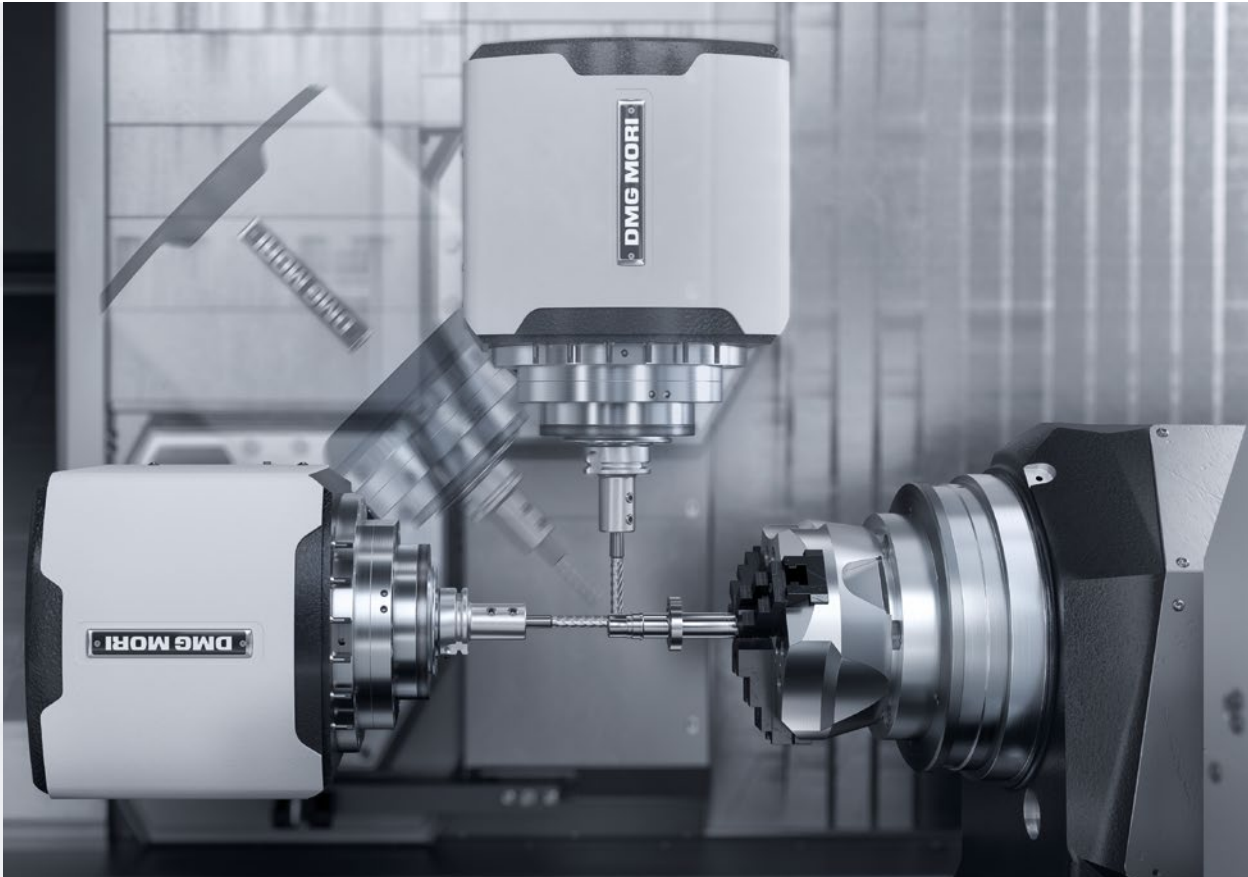

4 in 1 for full flexibility:
Radial and axial machining with one tool – on both spindles



Machine and technology

Machine configurator

Control and technology cycles

Applications

Floor plans/Working space/Technical data

CLX TC

compactMASTER

Optimum use of the workspace

- + Maximum usability of the working area thanks to the 350 mm short compactMASTER spindle
- + Face drilling of workpieces up to 300 mm long

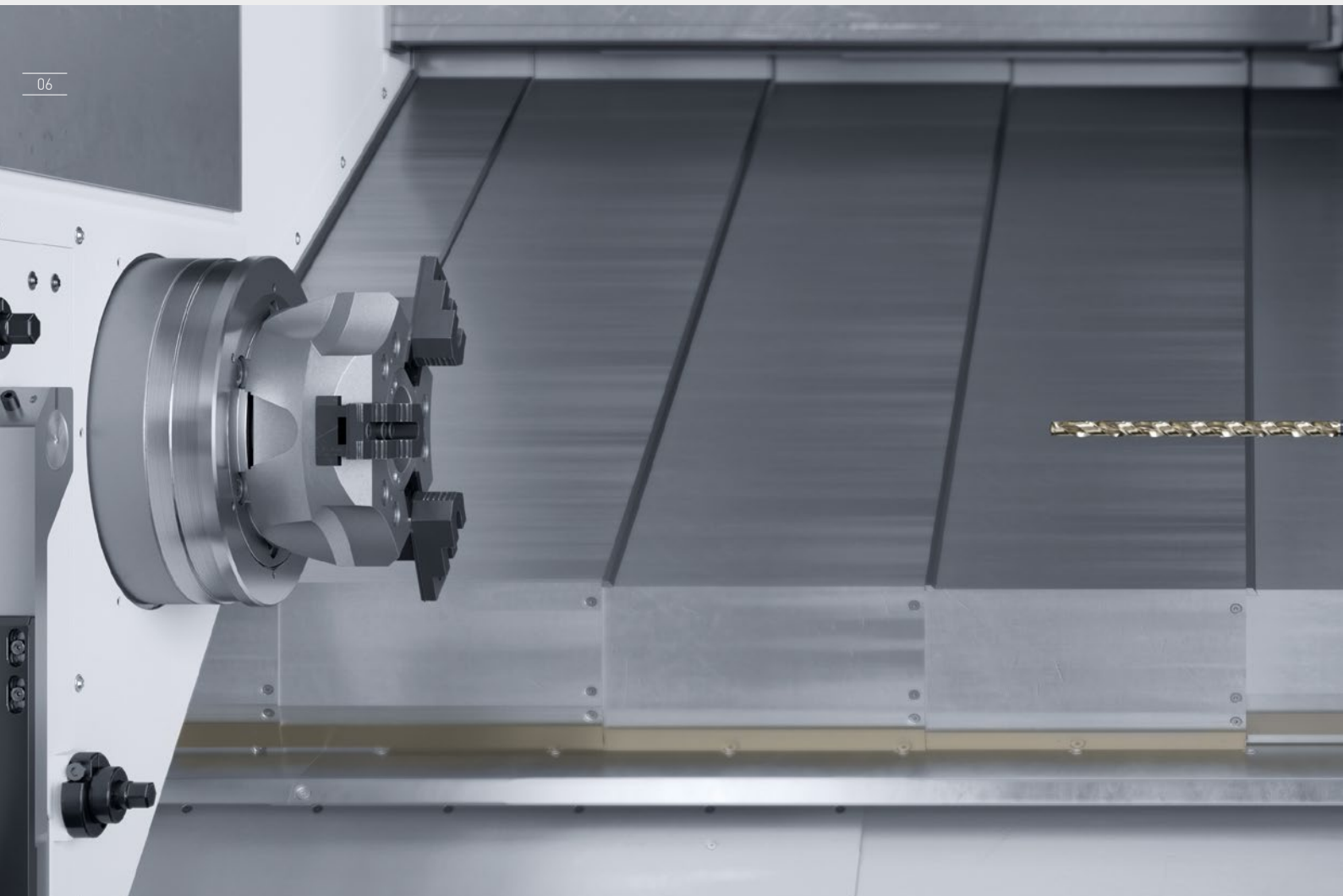
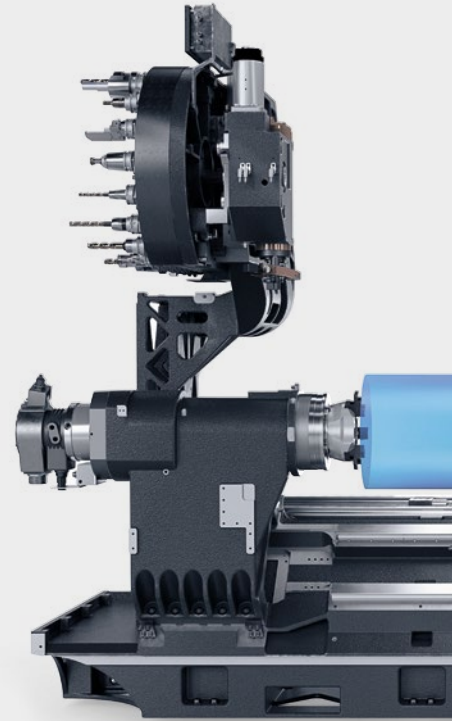

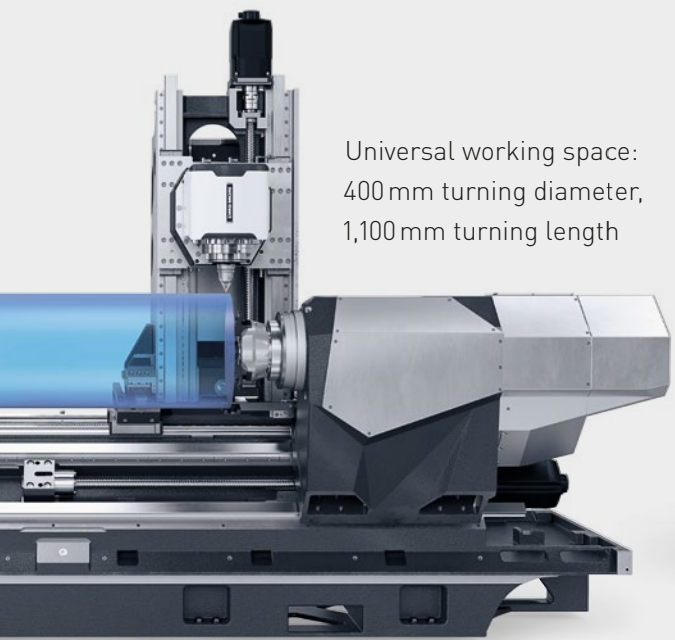
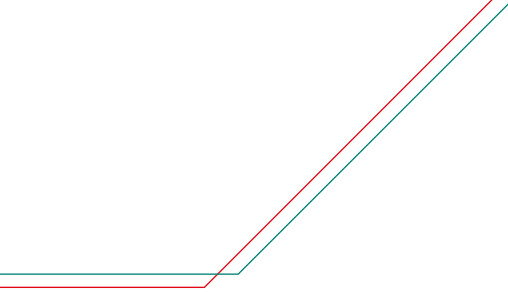

Universal working space:
400 mm turning diameter,
1,100 mm turning length

Collision-free working space for internal machining

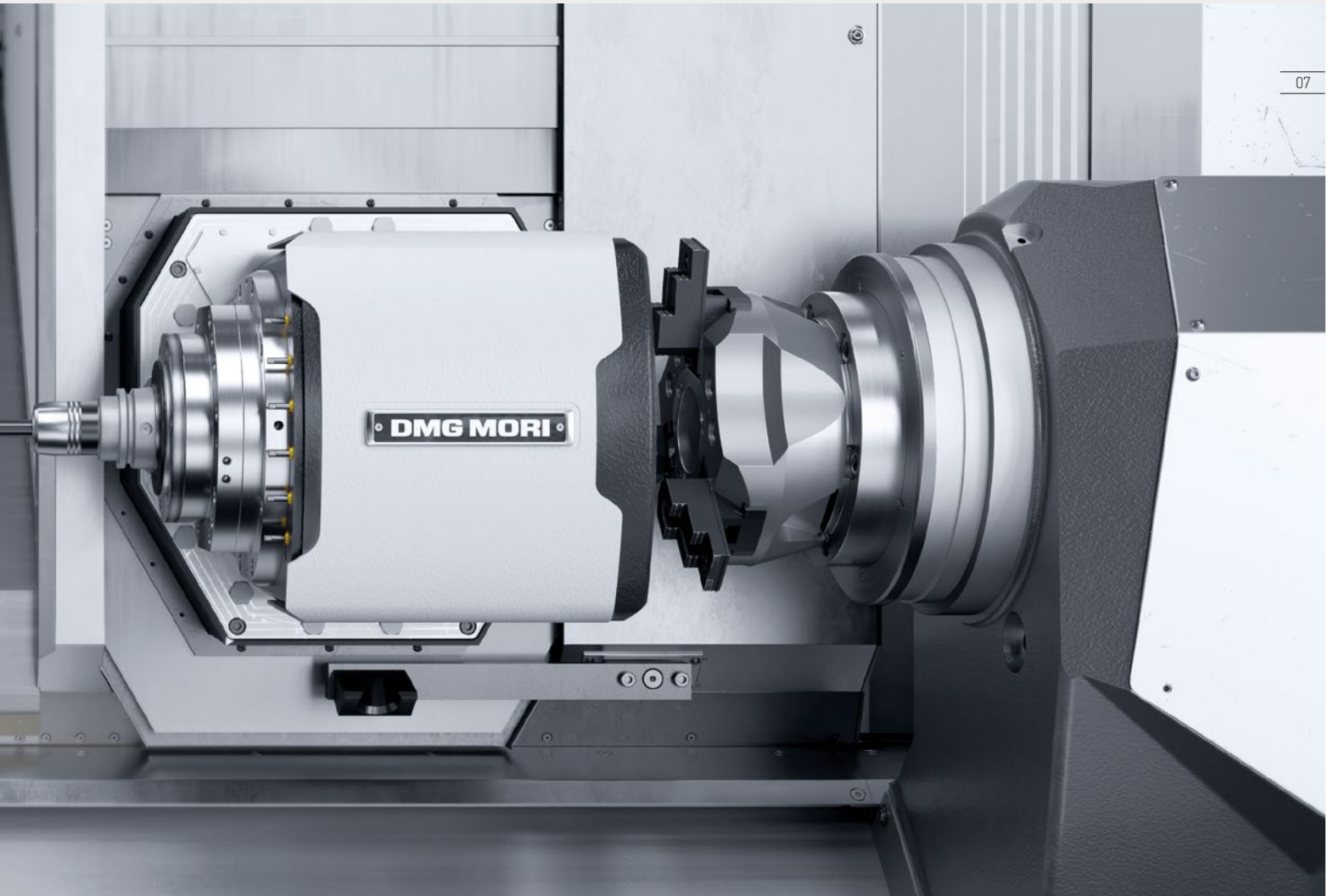
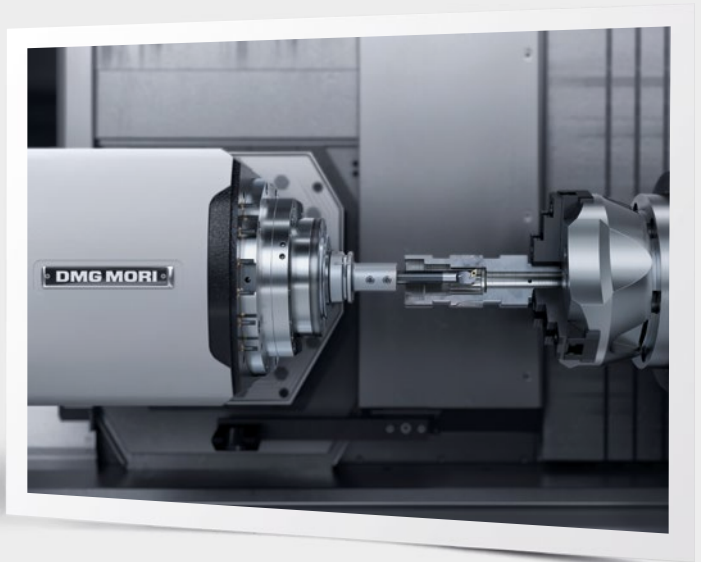

Machine and technology
Machine configurator
Control and technology cycles
Applications
Floor plans/Working space/Technical data

CLX TC

Modular, Stable, Accurate

A well-coordinated team

High-quality and proven components from the DMG MORI Group - designed for every application

30 tools
 HSK 63/Capto C6
 STANDARD

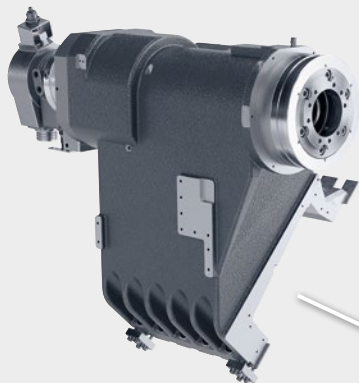

ISM 65, \varnothing 67 mm
 5,000 rpm / 345 Nm
 STANDARD

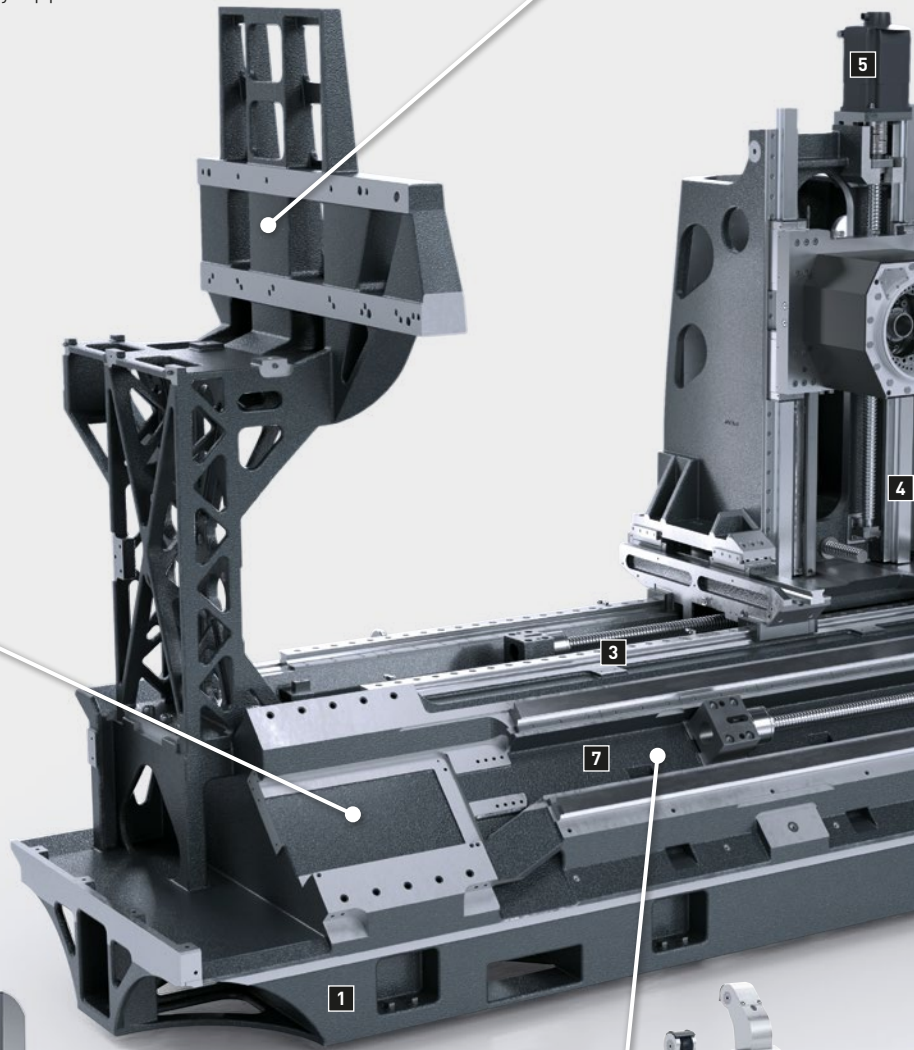

SIEMENS 840D sl
 19 inch multi-touch control system
 STANDARD

Steady rest
 SLU-X2/X3.1/X3.2
 OPTION

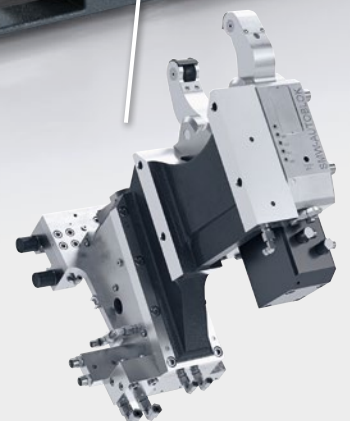



60 tools
HSK 63/Capto C6
OPTION



2



B-axis with torque motor
±120° swivel range,
0.001° angular resolution
STANDARD



compactMASTER
12,000 rpm, 90 Nm,
HSK 63/Capto C6
STANDARD

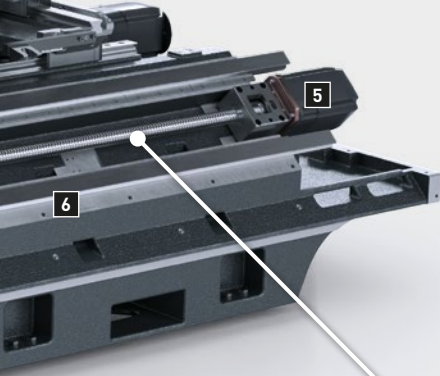

6

Tailstock MK 5
STANDARD



ISM 65, ø 67 mm
5,000 rpm / 345 Nm
OPTION

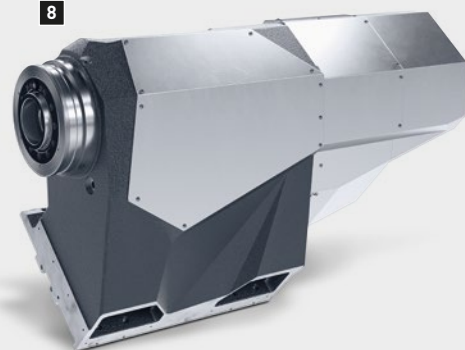

8

- 1 FEM-optimized cast bed**
For optimum stiffness and optimized vibration behavior
- 2 B-axis with Direct Drive**
for highest precision and dynamics
- 3 Constant rigidity**
Due to robust guideways up to size 45 and ø 40 mm ball screws
- 4 Wide guideway distance**
413 / 658 / 425 mm (X/Y/Z)
- 5 Thermostability**
Liquid cooling of all relevant components: spindle motors, X-/Y-/Z-axis drives
- 6 Protected Z-axis guide**
increases operational reliability and service life
- 7 Optimized chip fall**
45° bed and steep covers prevent temperature influence from hot chips
- 8 Machining independently**
Flexible machining strategies thanks to identical main and counter spindles

Machine and technology

Machine configurator

Control and technology cycles

Applications

Floor plans/Working space/Technical data

CLX TC

Non-stop production

Maximum automation in focus



compactMASTER with multitool holder

Multifunctional holders for faster
tool changes and even more space
in the tool magazine

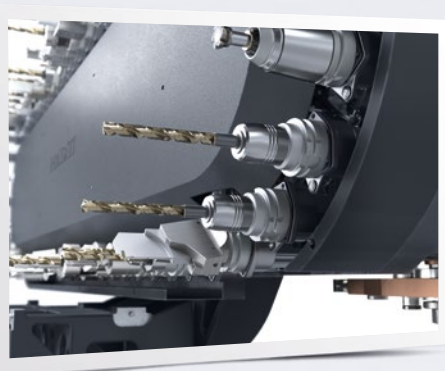

Sister tools

Sister tools reduce
machine downtime and ensure
greater process reliability



Increase process reliability

Multi-directional workpiece measurement
as well as tool measurement and drill
breakage control





Unrestricted access for the machine operator

Multijob

No tool set-up when manufacturing different workpieces

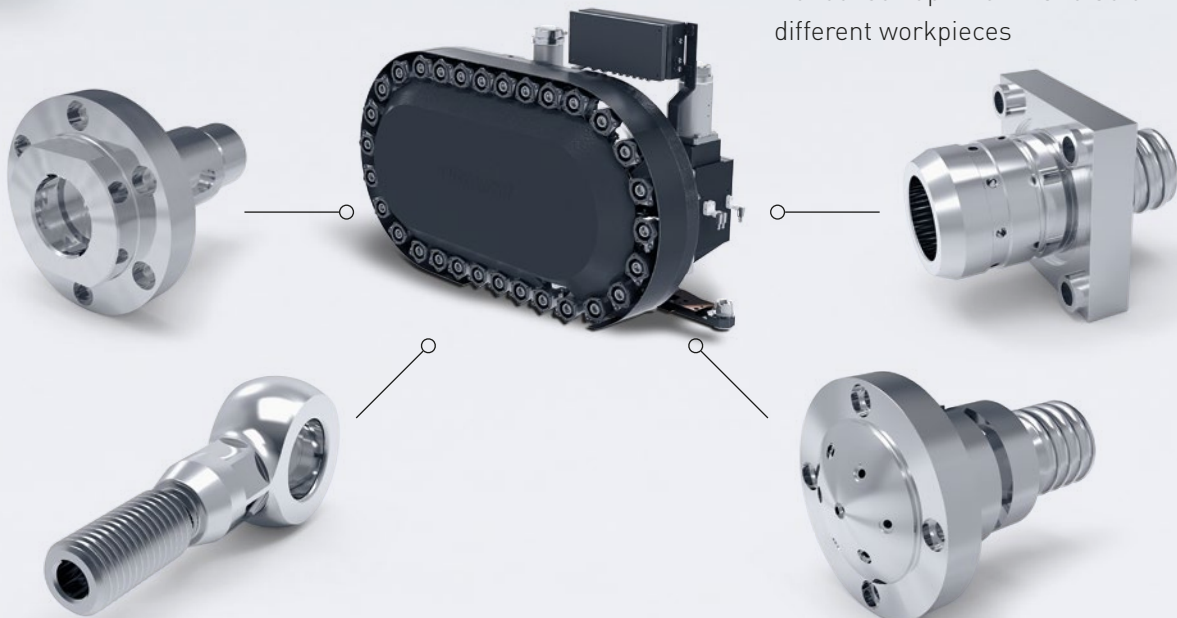

Machine and technology

Machine configurator

Control and technology cycles

Applications

Floor plans/Working space/Technical data

AUTOMATION

Perfect automation capability

Flexibility and productivity in harmony

Flexible workpiece handling up to 35 kg load capacity

- + Three versions for all requirements: Robot payload 10/20/35 kg
- + Handling of shafts $\varnothing 20 - 170$ mm, and chuck parts $\varnothing 20 - 175$ mm
- + External and internal gripping as standard
- + Customized workpiece trays and parallel use with bar feeder possible
- + Workpiece stacking
- + Financial security through simple changeover on turning machines



Robo2Go 2nd Gen.



Machine, automation and control – from a single source

- + Operation integrated in the machine control system via soft key
- + New software for dialog-driven, intuitive operability
- + No robot programming knowledge, as well as adaptation of the NC program necessary
- + Multijob function: Different jobs on one workpiece tray. Ideal for small and medium batch sizes
- + Creation of the process using predefined program modules via drag & drop
- + Easy creation of individual workpiece trays

Short bar loader - the simple solution for loading bar material

- + Maximum productivity with a small footprint
- + Quick adjustment of the diameter
- + Process-reliable feeding of rotationally symmetrical profile material
- + Optimum material guidance right into the clamping device
- + Rod diameter 6 – 65 mm and max. 1.500 mm length
- + User-friendly, mobile control for secure communication with the machine
- + Easy access to the machine thanks to transverse/longitudinal shift system



The perfect combination

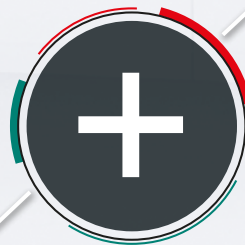

Integrated pick-up device The simple solution for unloading workpieces

- + Easy removal of the finished part on the left side of the machine
- + Unique: conveyor belt behind the machine hood without restriction of intervention
- + Complete chip protection: workpiece catcher is swiveled in from outside the working area
- + For workpieces up to $\varnothing 80 \times 200$ mm and a max. weight of 6 kg

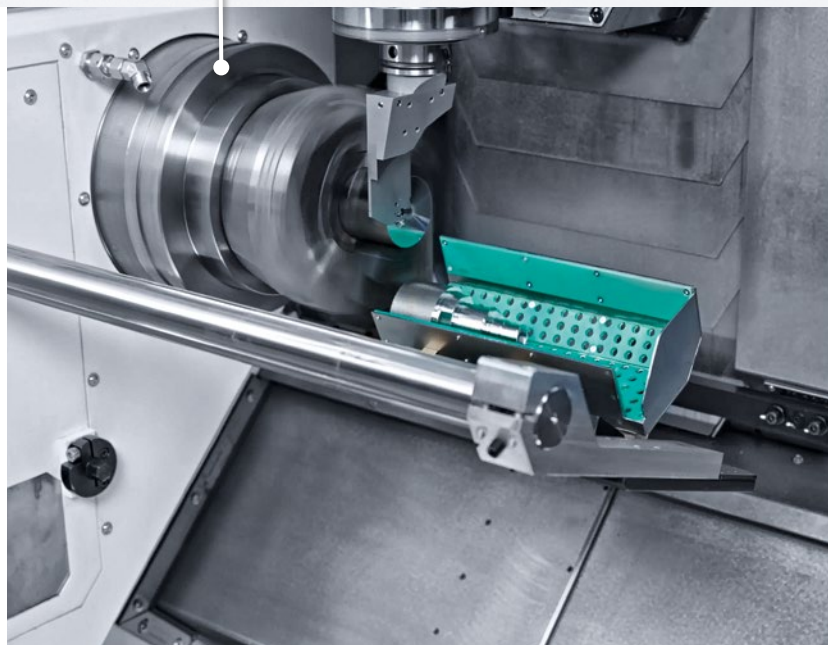

CONFIGURATOR

Lines and packages

Secure your special prices

- + Convince yourself of the great equipment quality and configure your machine freely according to your needs
- + Take advantage of our pre-specified equipment lines and option packages at special prices



BASIC

Basic equipment with maximum freedom of configuration

COMPLETE

Complete machining with the most important options

COMPLETE *plus*

Complete machining for maximum flexibility

EQUIPMENT LINES

OPTIONAL PACKAGES



24/7



Bar feeder



Automation

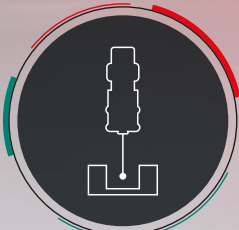

Measure



Steady rest

CONFIGURATOR

Guidepost

Harvesting success with the right equipment

- + Take it into your own hands and use the new DMG MORI machine configurator
- + Make the specification of your future machine your own experience
- + Choose your desired equipment line based on your requirements

BASIC

Functional entry

The basic variant contains basic equipment that lets you get started right away.

Equipment

- + Main spindle ISM 65
- + Hollow clamping device
- + compactMASTER turn-mill spindle
- + Hydraulically movable tailstock
- + 30-station chain magazine
- + Chip tray
- + Duplex filter
- + Direct measuring systems in X and Y axis
- + Electronic handwheel
- + DMG MORI IoTconnector

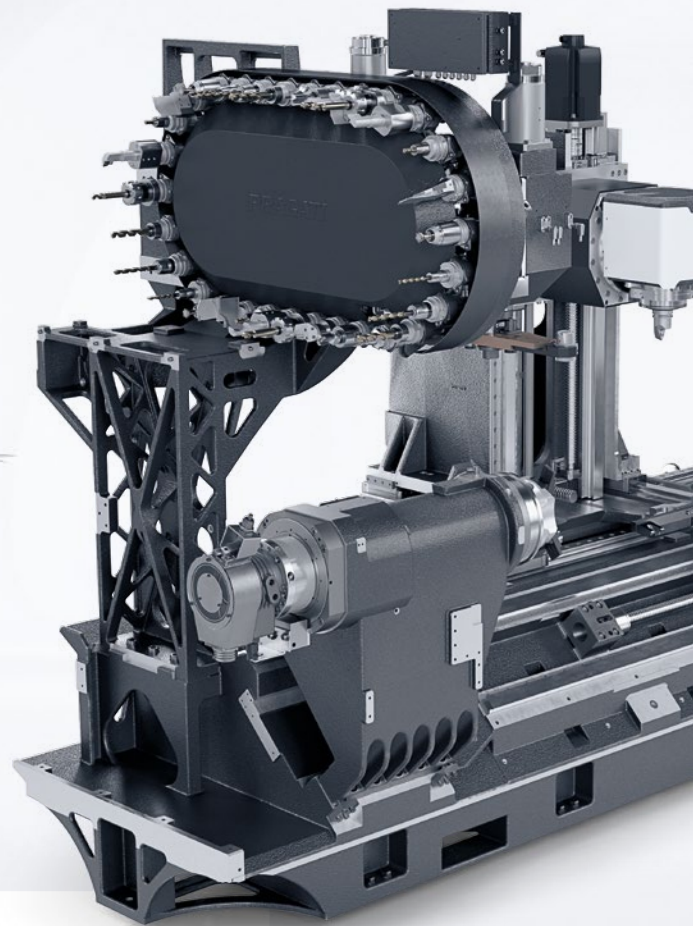

Simply attractive

The equipment line Complete provides the perfect entry into complete machining thanks to counter spindle and other important options.

COMPLETE

Equipment

IN ADDITION TO BASIC

- + Counter spindle ISM 65
- + Chip conveyor
- + Safety glass cleaning
- + Chuck flushing device for main and counter spindle
- + Coolant spray gun
- + Technology cycle:
 - Alternating speed

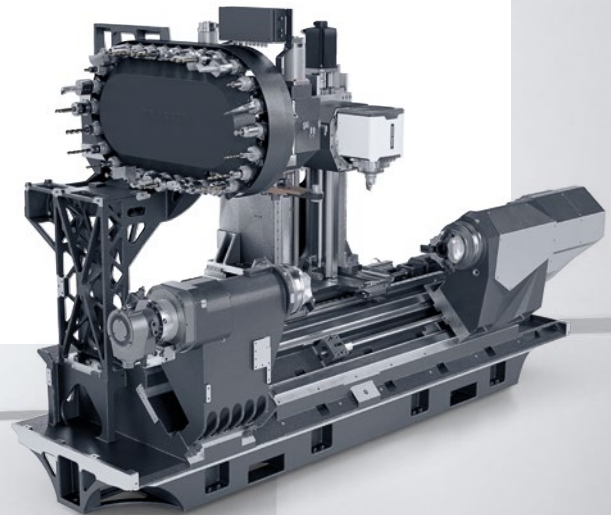

Fascinatingly complete

With COMPLETE *plus* no wishes remain unfulfilled. More tools, more technology, more options for maximum flexibility at the most attractive price.

COMPLETE

plus

Equipment

IN ADDITION TO COMPLETE

- + 60-station chain magazine
- + Tailstock function for the counter spindle
- + Tropical Package
- + BDE interface
- + Technology cycles:
 - Excentric turning and milling
 - Multi threading 2.0

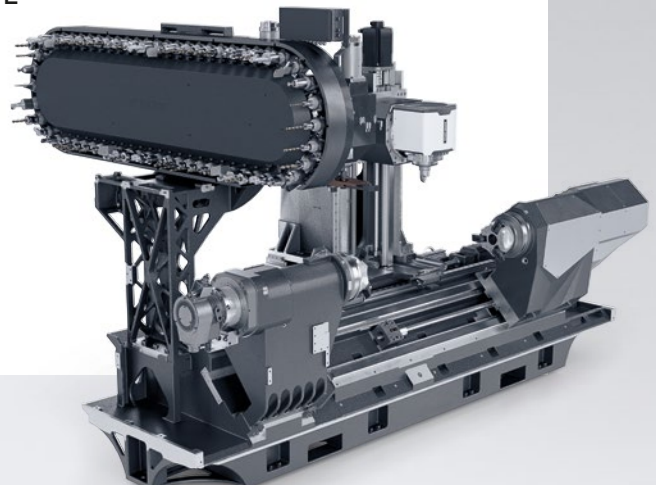

CONFIGURATOR

Variety

Discover your possibilities

Customize your machine to your needs with attractive option packages

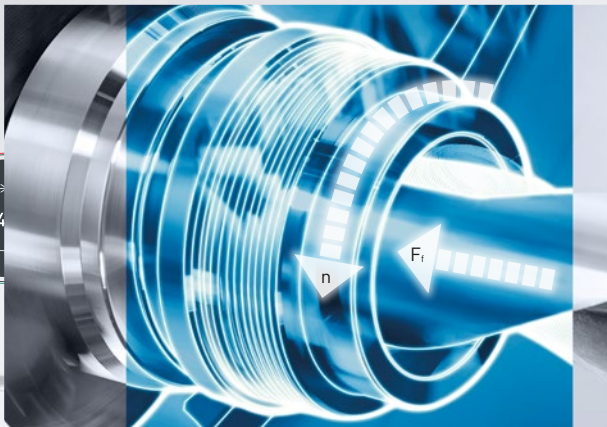

PACKAGE

24/7

Without break. Exactly. Safe.

980l coolant tank incl. band filter system and temperature control, oil mist separator and Easy Tool Monitor 2.0.



PACKAGE

Bar feeder

Staying with the bar.

Rely on the combination of short bar loading magazine, workpiece pickup device, Y-axis grooving and collet chuck.



PACKAGE

Automation

Automatically into the future.

Additional coolant feeds, Robo2Go interface, signal light and electric machine door point the uncompromising way to a common, automated future.

PACKAGE

Measure

Precise to the point.

Integrated tool measurement, tool touch probe and direct measuring system in all axes for highest machine accuracy and unmatched workpiece control.



PACKAGE

Steady rest

Everything under control at all times.

Material sagging? Take remedial action with automatically positionable steady rest slides, quick-change system and steady rest.

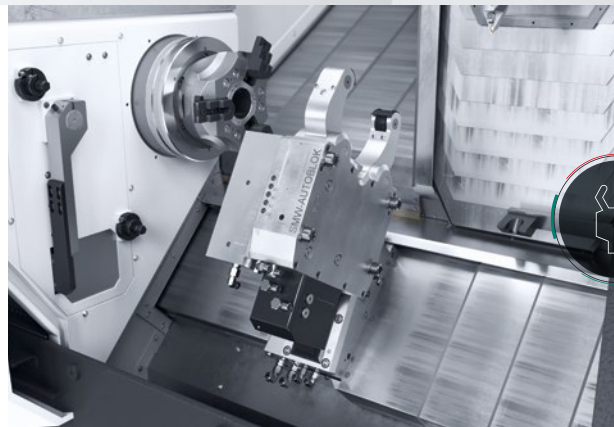

Not enough yet?

Then customize and finalize your machine with individual options to meet your needs 100%. For example:

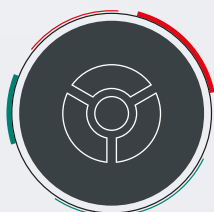

Power chuck

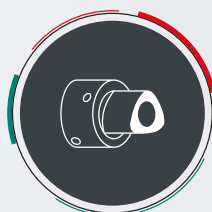

Capto C6



Finest chip package



Oil mist separator

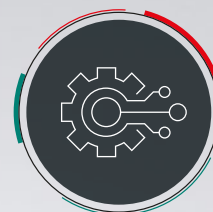

Technology cycles

CONTROL

DMG MORI SLIMline Multi-touch control for easy use and maximum efficiency

- + 19"-multi-touch control and Operate 4.9 on SIEMENS
- + Extended memory capacity
- + 3D control technology



19" DMG MORI multi-touch control panel and SIEMENS

MORE EFFECTIVE OPERATION

- + Better workflow, higher efficiency
- + Fast and convenient access to parameters and user data
- + Program selection: Extension to local drive/USB/network
- + Multitask machining: Extended drilling cycle for drilling/through-hole drilling; program guidance with new deep-hole drilling technology
- + Execution from external memory: Viewing and saving additional file formats
- + Advanced simulation: definition of workpiece supply by clamps; simultaneous recording
- + DMG MORI SMARTkey: Personalized authorization and extension with USB memory with 8 GB

MORE COMFORTABLE USE

- + Better overview thanks to 19-inch screen: higher resolution and the innovative convenience of intuitive use with unique functionality
- + 3D control technology: workpiece and machining simulation via touch operation
- + Flexible software keyboard: Integrated into the multi-touch display
- + Effective and secure editing with content access button on the control panel
- + Optimized ergonomic: with 45° swivel range
- + Reliable, scratch-resistant surface for operation

Easier and faster from drawing to workpiece.

Machine setup

Special measuring cycles facilitate the measurement of the tools and the workpiece.

Create program

Effortless programming of the workpiece thanks to graphical support. G-code programming knowledge is not required.

Manage tools

ShopTurn saves your tool data. The software can also manage data of tools that are not in the magazine.

Manage programs

You don't need to create similar programs from scratch, you can easily copy and modify them.

CONTROL

SIEMENS with ShopTurn 3G Well equipped, simply machined

- + Dialog-guided programming with graphical support
- + 3D-graphics including real-time simulation
- + Clear screen design
- + Traffic light diagnostics for all drives

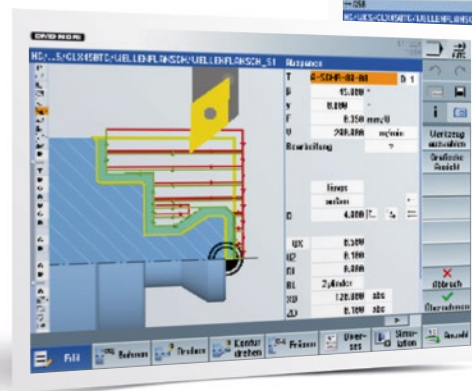

ShopTurn is an operating and programming software for turning machines that allows you to comfortably operate the machine and easily program workpieces.

CLAMPING PRESSURE ADJUSTMENT

The right clamping pressure for every clamping situation: Clamping pressure adjustment conveniently directly on the control unit.



DMG MORI TECHNOLOGY CYCLES

Exclusive technology cycles

Complex machining simply realized

DMG MORI exclusive technology cycles are the true assistants of the production-oriented programming to increase productivity and safety as well as to extend machine capability.

- + Proper program structure
- + Program up to 60% faster
- + Error minimization by dialog-guided programming
- + Technology know-how stored in the program

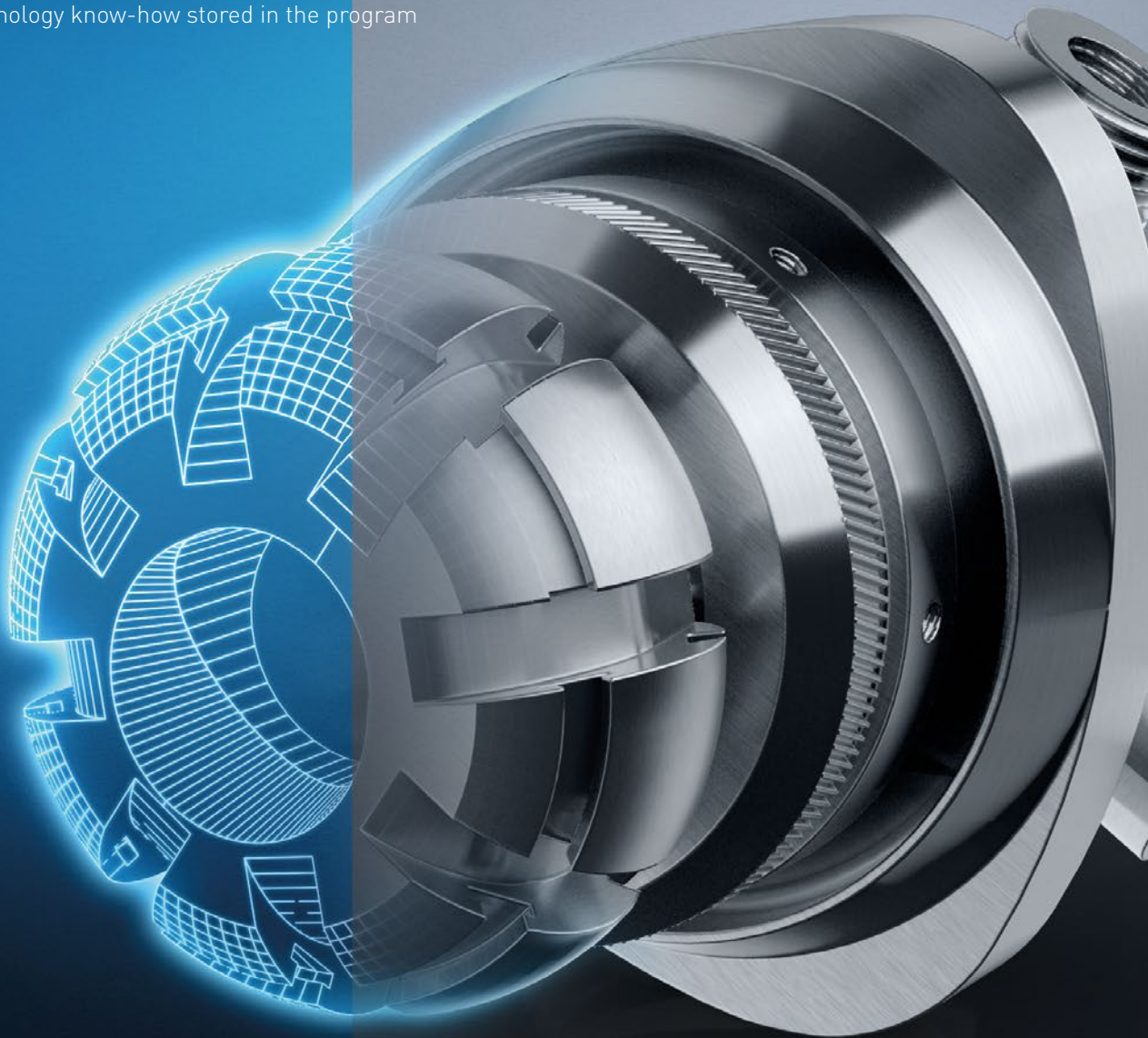

Handling

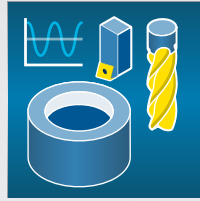

Alternating speed

Only three parameters and I can very pragmatically avoid vibration problems in the processing.



Counter spindle tip

The fully automatic changing of the counter spindle tip saves me a lot of time for manual setup during machining.



autoCHUCK

A perfect addition for my machines. I save time and can increase the quality of my components at the same time.

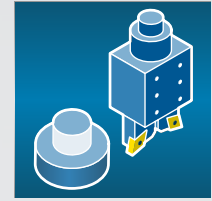

Multitool

Non-productive times have decreased significantly and I need fewer places in the tool magazine.

Machining

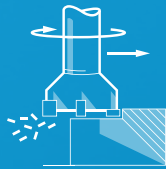

Keyway broaching

The high flexibility in creating grooves according to DIN6885 or DIN138, inside or outside, narrow or wide, short or long is simply great!

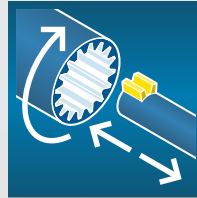

Gear broaching

Thanks to this cycle, I can produce internal and external gears more easily than ever before. The program can be created safely using clear input parameters."

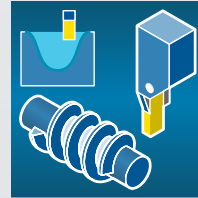

Multi-thread cycle 2.0

Without an expensive CAD/CAM system, I can create complex threads and screw geometries directly on the machine.

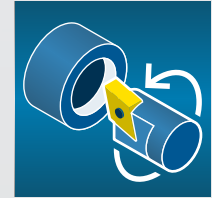

Interpolation turning

I can do turning operations even though I don't own a lathe, and even off-center.



Gear hobbing

Thanks to dialog-based programming I'm up to 50% faster.



Eccentric turning and milling

Instead of using a complex CAD/CAM system, I enter only a few parameters here.

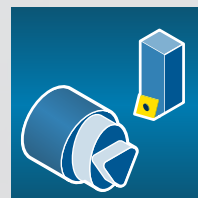

Polygon/Oval Turning

By synchronizing the spindle and driven tools, I can produce non-circular surfaces significantly faster.



Y-Axis Parting

The new highly productive cut-off method via the Y-axis is amazingly easy and safe to operate with the technology cycle.

Monitoring



PROTECTION PACKAGE



Machine Protection Control

Since using MPC, I have had no spindle or machine damage due to overload or collision.

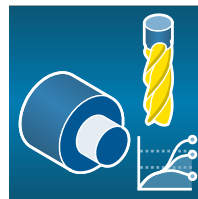

Easy Tool Monitor

Finally a simplified system, to save money for unnecessary machine repairs and tool costs.

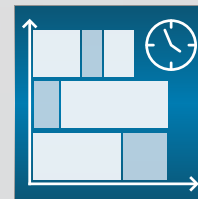

Runtime monitor

I save a lot of machining time, because thanks to the graphical monitoring I can now optimize my programs very easily and quickly.

Machine and technology
Machine configurator
Control and technology cycles
Applications
Floor plans/Working space/Technical data

APPLICATIONS

Reinvented the wheel? Chain wheel machining simply productive

- + Highly productive and simple machining of complex operations with the help of exclusive DMG MORI technology cycles
- + Thanks to an innovative machining solution, several chain wheels can be machined in a simple way in one clamping operation

Deburring

Y-Axis Parting

The new highly productive cut-off method via the Y-axis is amazingly easy to operate with the technology cycle

- + Compatible with the standard CYCLE92 cycle (Part off cycle), allowing the operator to program as usual (ShopTurn und DIN/ISO)
- + Up to three times higher productivity possible (3-times feed rate) with improved chip control at the same time

Gear hobbing

Programming of the gear parameters of spur, helical, curved and worm gears via dialog input.

- + Tooth profile modifications easily manageable
- + Consider the use of reground tools
- + Error prevention through monitoring (e.g. incorrect axis cross angle or incorrect speed or direction of rotation)

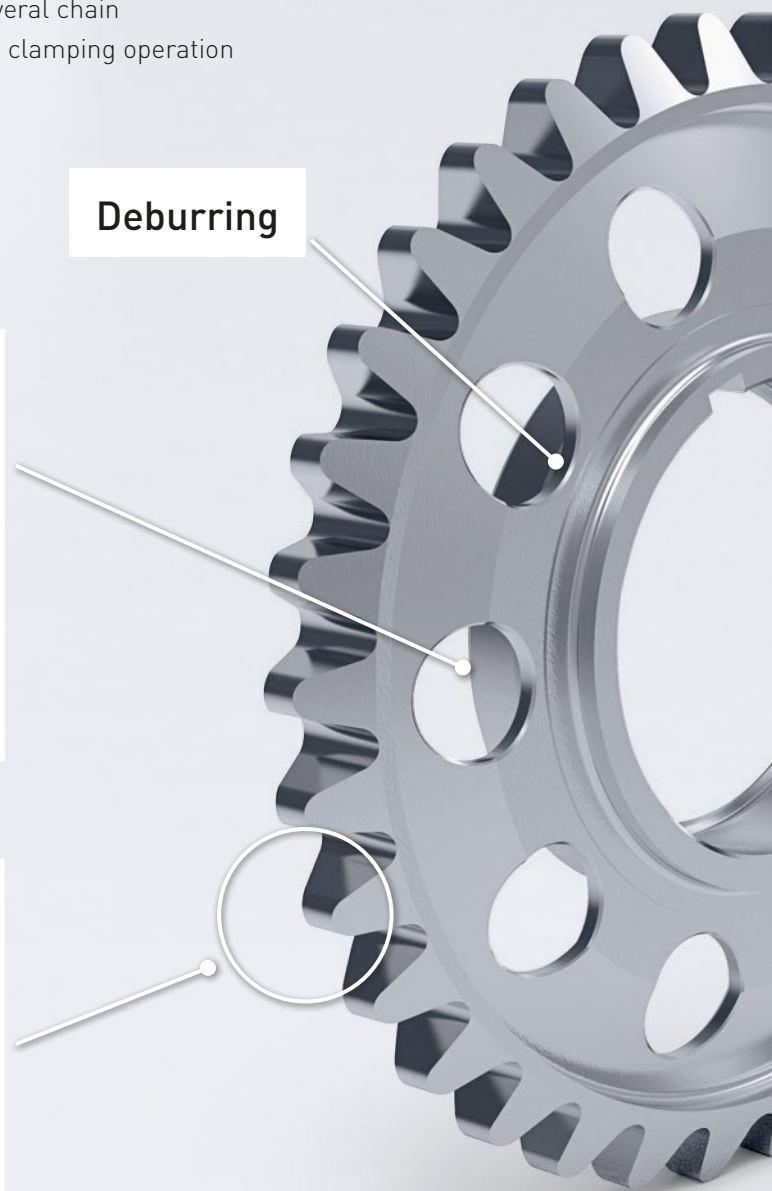



Axial grooving

Keyway broaching

Flexibility in creating grooves according to DIN 6885 or DIN 138, inside and outside, narrow or wide, short or long with standard tools on standard machines

- + Structured input parameters for the slot geometry, the tool and the machining strategy
- + Advantages of the rigid machine guide for better groove quality

Drilling

Internal turning/radial grooving

FactBox

Material:	16MnCr5
Dimensions:	∅118 × 15 mm
Number of teeth:	35
Module:	2
Machining time:	14.8 Min.
Number of tools:	11 vs. 15
(CLX TC vs. turret)	

APPLICATIONS

Unmatched universality

No limits in head piece machining

- + Benefit from universality for components with complex structures and a wide variety of operations
- + With the help of SIEMENS ShopTurn 3G and the exclusive DMGMORI technology cycles, workpieces can be programmed in a dialogue-guided manner thanks to graphic support

Easy Tool Monitor 2.0

Drive load monitoring of the tools during the machining process to prevent damage to the machine and operating equipment.

- + Saving the monitoring limits for each tool and cutting edge in the program
- + NEW: Powerful algorithm for efficient monitoring after the first workpiece

Polygon- /Oval-Turning

Programming and fine adjustment of the required shape, polygon or oval, can be realized in a few steps

- + Easy editing of non-circular parts with the help of the intuitive user interface
- + Production of the required geometries with simple possibilities of fine corrections
- + Machining inside and outside, as well as on main or counter spindle combinable

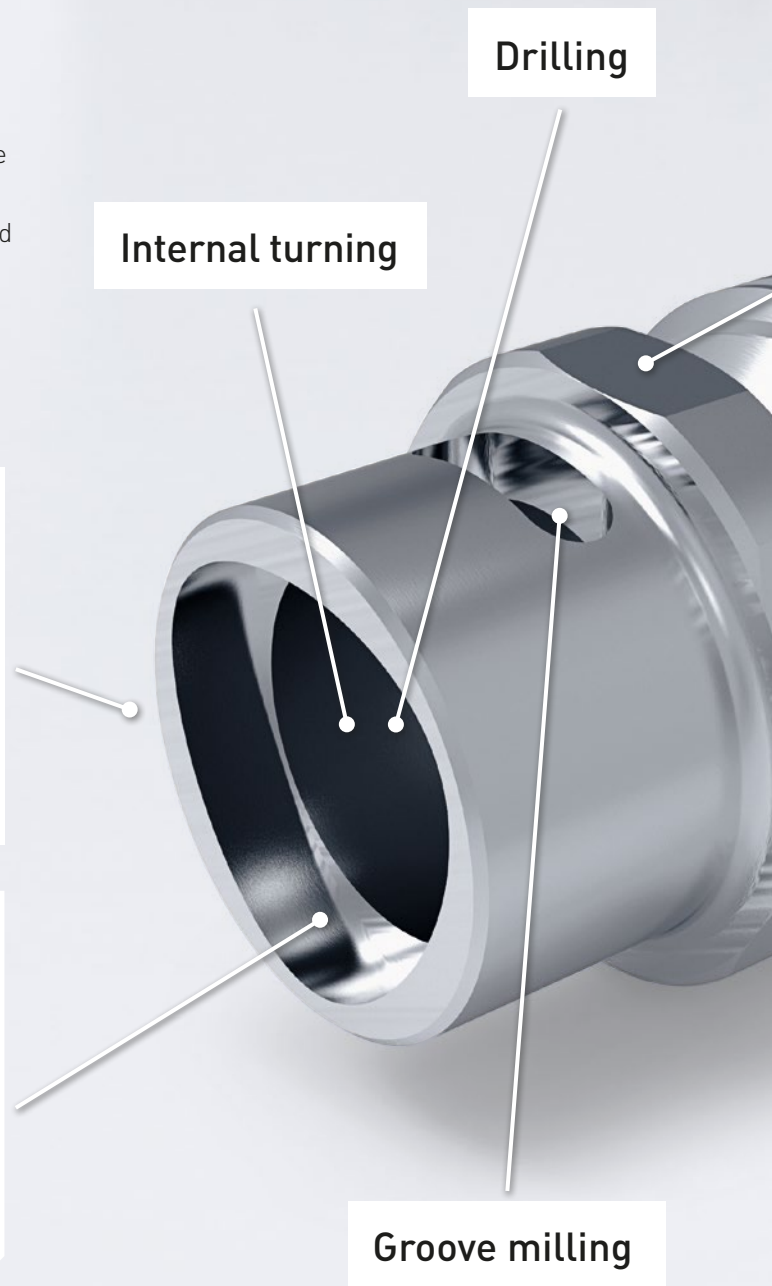



FactBox

Material:	16MnCr5
Dimensions:	ø100 × 186 mm
Wrench size:	96
Thread pitch:	3.5 mm
Machining time:	40.6 min.
Number of tools:	11 vs. 14 (CLX TC vs. turret)

Milling

Drilling

Multi-threading 2.0

Creation of large movement- or special threads that cannot be produced by simple thread chasing

- + Trapezoidal, buttress- and round threads easily programmable on the machine
- + Screw conveyor with any profile geometry
- + Free definition of contours, gradients and gears possible
- + NEW: On-Point Threading - Position-oriented thread generation

APPLICATIONS

Out of round? Still runs round!

Camshaft machining without restriction

- + Thanks to the stable machine design, even imbalances can be handled
- + The capability of axis simultaneity allows parts with free-form surfaces, such as cams, to be completely manufactured in a universal machine.

Simultaneous milling

Simultaneous interpolation of up to four axes (here: X, Z and C axis)

Axial grooving

FactBox

Material:	16MnCr5
Dimensions:	ø 60 x 136 mm
Excentricity:	3.5 mm
Machining time:	8.7 min.
number of tools:	7 vs. 11 (CLX TC vs. turret)

Drilling/Internal turning



Radial grooving / external turning

Internal turning

Counter spindle tip

Cycle for automatically changing a tailstock center into the chuck of the main or counter spindle via the tool carrier

- + Support of long and slim workpieces in the main spindle by synchronously running counter spindle tip
- + Perfect combination for 6-sided complete machining and tailstock function

Alternating speed

Changing the spindle speed to avoid vibration of tools during machining

- + Easy to operate with three parameters and without additional sensors
- + No manual intervention by the operator
- + Identical repeatability for all components
- + Increased process reliability for special application by avoiding vibrations

DMG MORI

For the sake of the environment

Energy efficiency and CO₂ neutrality



Energy efficiency measures

- 1 Frequency controlled hydraulic power unit
- 2 Cooling unit with precision control
- 3 Controlled switch cabinet cooler
- 4 Clocked chip conveyor
- 5 Regulated cooling lubricant pumps
- 6 Brake energy recovery from spindles and feed drives
- 7 Direct drive with synchronous motor
- 8 LED workspace lighting
- 9 DMG MORI AUTOshutdown for the shutdown after program end

Construction

FEM-optimized design with high static and low moving masses

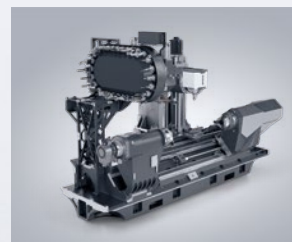

Servo technology / frequency control

Frequency-controlled coolant and hydraulic pumps, instead of fixed displacement pumps with throttle technology

High Efficiency ↑	IE4 Super Premium Efficiency
	IE3 Premium Efficiency
EFF 1	IE2 High Efficiency
EFF 2	IE1 Standard Efficiency
IEC Engines	

Motor – use of state-of-the-art drive motors with efficiencies of up to 93%

Cooling* – Inverter-controlled systems for demand-oriented cooling capacity

*Option



- + Sustainable and holistically strong for the environment: DMG MORI will manufacture all machines completely climate-neutral from 2021 - from raw material to delivery
- + Key role in the production of green technologies: DMG MORI's machines and manufacturing solutions also operate with maximum energy efficiency in the customer's plant
- + DMG MORI bundles its holistic climate neutrality initiatives into three areas:

100 % CLIMATE-NEUTRAL MACHINE PRODUCTION

SUPPLIER + **DMG MORI**



NEUTRAL CO₂ FOOTPRINT OF ALL DMG MORI MACHINES - FROM RAW MATERIAL TO DELIVERY

1. NEUTRAL PRODUCT CARBON FOOTPRINT

All machines delivered from January 2021 onwards will be manufactured in a climate-neutral manner

2. NEUTRAL COMPANY CARBON FOOTPRINT

DMG MORI has already been climate-neutral in its own value creation since May 2020.

MACHINE USAGE

CUSTOMER



ENERGY- AND EMISSION-EFFICIENT MACHINE OPERATION

1. Up to 30% energy savings compared to the previous machine
2. Provides access to many government funding programs - contact us!



TECHNOLOGY EXCELLENCE FOR GREEN TECHNOLOGIES

1. Green technologies such as wind power and electromobility are the most important lever against the Climate change
2. DMG MORI is the innovation driver for the production of green technologies

DMG MORI

One step more digital – with the IoTconnector as standard

IoTconnector:

- + DMG MORI NETservice and MESSENGER pre-installed
- + Quick and easy installation in the control cabinet via LAN cable
- + Preconfigured specifically for your machine before delivery
- + Standard interfaces enable fast and efficient data exchange
- + Integrated firewall with automatic updates guarantees maximum protection for your machine

SERVICEcamera:

- + Direct livestream to the hotline via NETservice
- + Plug-and-play function through pre-configuration for IoTconnector
- + Fast and secure 5G WiFi transmission
- + Splashproof housing
- + Integrated magnet for mounting the camera
- + Light and laser pointer integrated

NETservice

- + Shorter waiting times, thanks to routing directly to the next available employee
- + Higher resolution rate through access to IPC and NC
- + Maximum data security
- + Optional connection of the SERVICEcamera: More efficient problem solving thanks to live stream (video/audio/image) from the machine directly to the DMG MORI hotline
- + Multi-user conference = inter-connection of various DMG MORI specialists for joint, faster problem solving
- + Also for existing machines thanks to retrofit kit



DMG MORI Finance – Into the future with in-house financing

With our in-house financing solutions, we offer our customers unique opportunities – even when banks and other leasing companies scale back their activities in economically challenging times

- + Repayment-free period of up to six months
- + Full flexibility through staggered rates depending on utilization
- + Low monthly charges due to high residual values
- + Financing of overhauls, training and full service
- + Flexible contract adjustments even during the fixed term
- + Attractive follow-up financing after the agreed term
- + Sale-and-lease-back transactions for more cash flow

LEASING

- + Full amortization, partial amortization or operating lease with individual installment scales
- + Maximum investment scope thanks to high residual value and low rates

RENT

- + Terms from 12 months
- + Return, extension or purchase at the end of the term

RENTAL PURCHASING

- + Reduced initial rates protect liquidity in the first 6 – 12 months
- + Unscheduled repayment once a year free of charge
- + DMG MORI Finance grants you sufficient time for payment of the VAT portion due immediately
- + Consideration of subsidies in the drafting of contracts



CLX TC

Floor plan

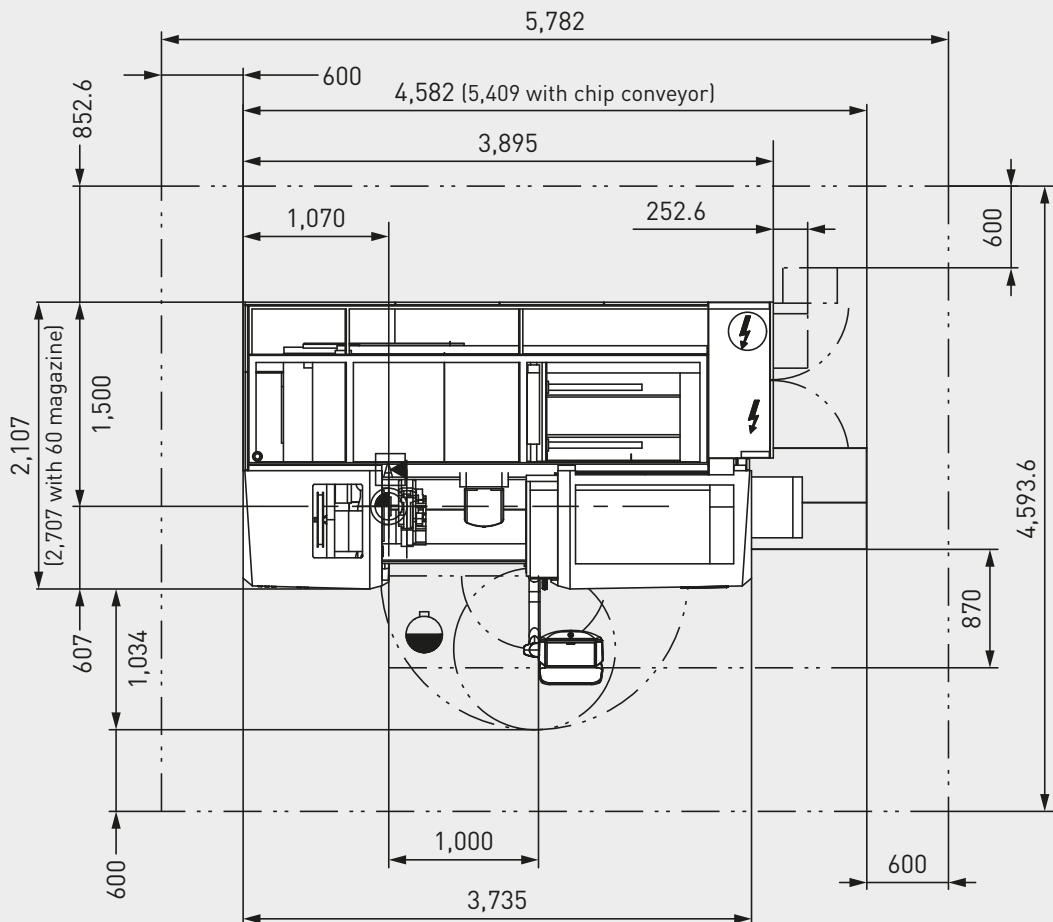
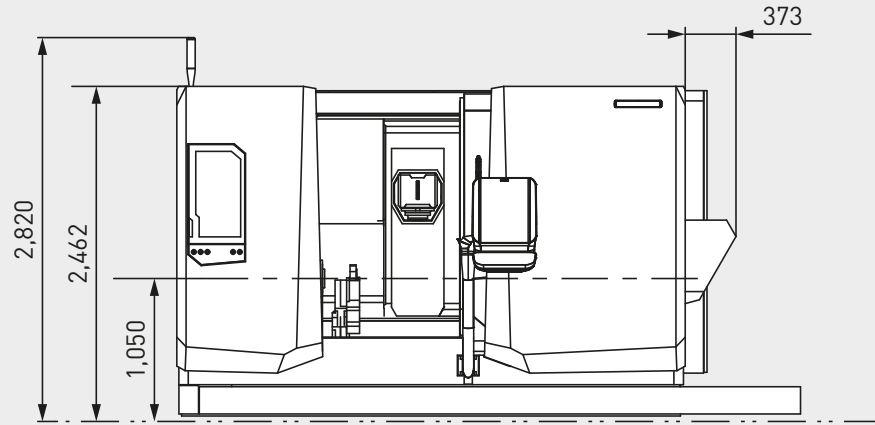

Work area

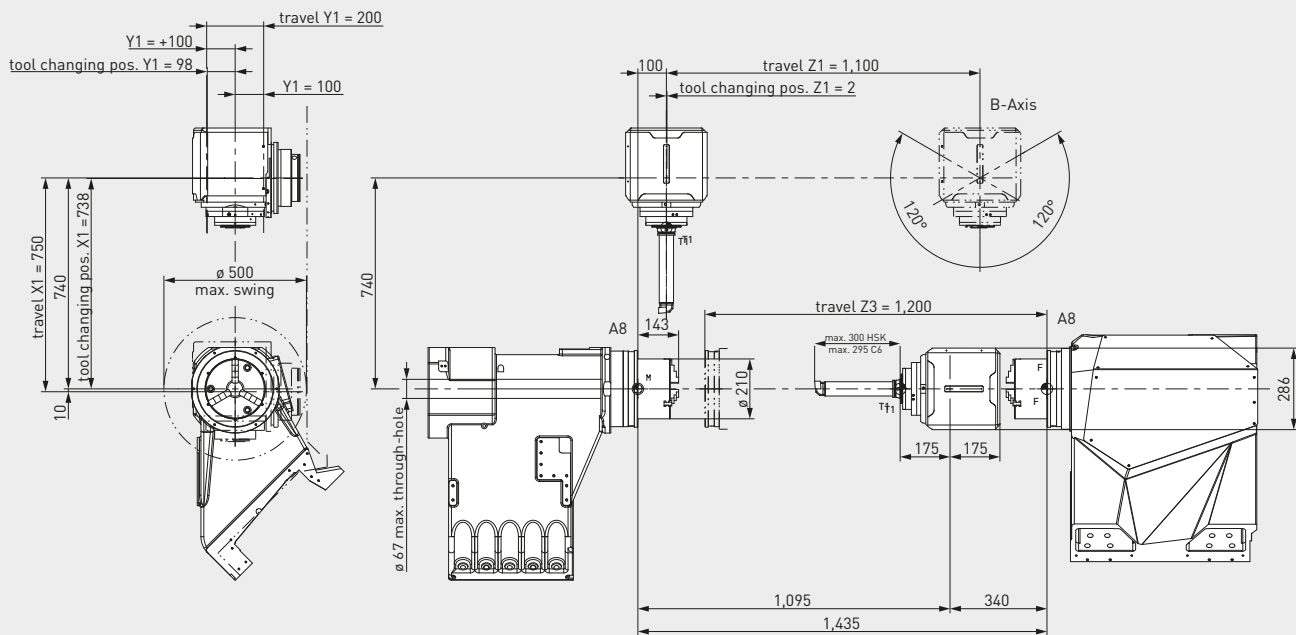
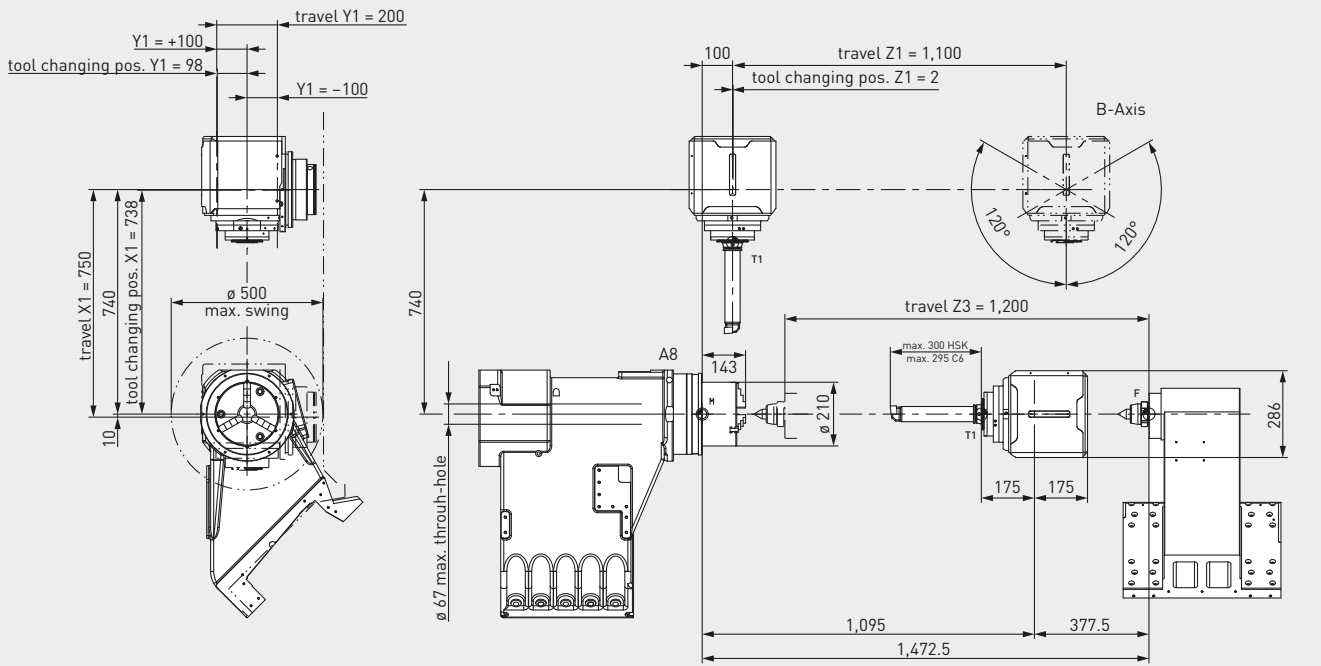

CLX TC

Power diagrams

Main and counter spindle ISM 65
 5,000 rpm / 17 kW / 345 Nm (40% ED)

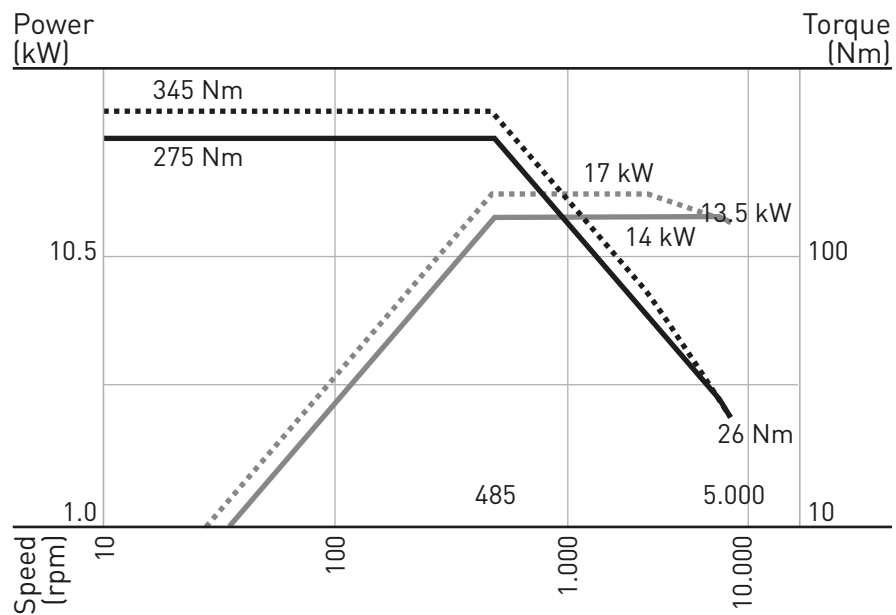

compactMASTER – Standard
 12,000 rpm / 10,5 kW / 90 Nm (40% ED)

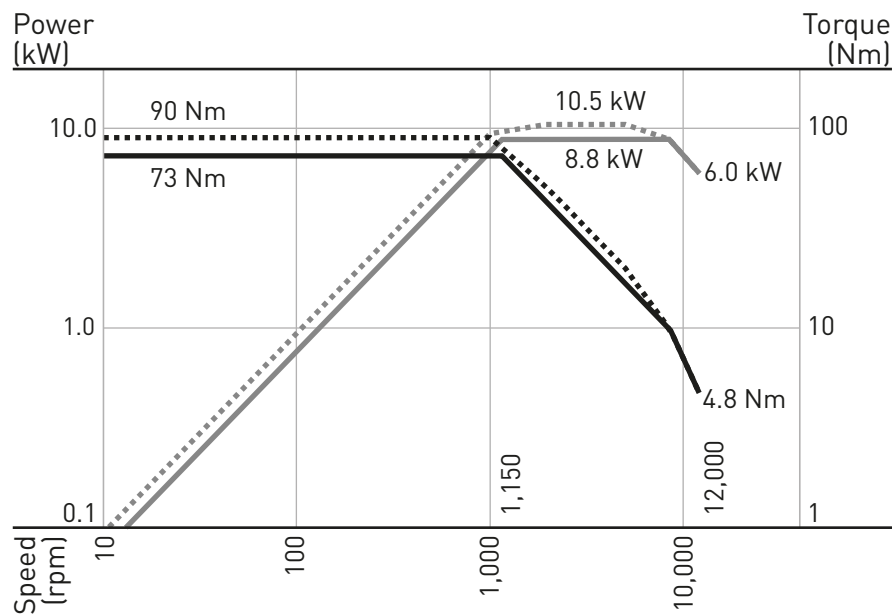

Technical data

Workspace		
Max. swing diameter	mm	500
Max. turning diameter	mm	400
Distance main spindle to tailstock (without chuck)	mm	1,473
Distance main spindle to counter spindle (without chuck)	mm	1,435
Max. turning length	mm	1,100
Main and counter spindle ISM 65		
Max. speed	rpm	5,000
Drive power /torque (40 % ED)	kW/Nm	17/345
Diameter in front bearing	mm	120
Clamping tube inner diameter	mm	67
Spindle nose (short taper)		A8
Max. chuck diameter	mm	325
B-axis with turn-mill spindle		
Tool holder		HSK 63 [Capto C6]
Number of tool stations		30 (60)
Spindle speed	rpm	12,000
Drive power /torque (40 % ED)	kW/Nm	10.5/90
Swivel range B-axis	°	±120
Rapid traverse B-axis	rpm	70
Slide for B-axis		
Travel X/Y/Z	mm	750/±100/1,100
Rapid traverse rate X/Y/Z	m/min	40/40/40
Feed force X/Y/Z (S3 – 40%)	kN	9.5/7.5/10
Slide for counter spindle		
Travel Z	mm	1,200
Rapid traverse rate Z	m/min	40
Feed force Z (S3 – 40%)	kN	10
Tailstock		
Stroke (hydraulic)	mm	102.5
Quill Power	kN	8
Tailstock centre	MK	5
Machine		
Footprint	m ²	7.1
Discharge height chip conveyor	mm	995
Machine height	mm	2,820
Machine weight	kg	9,000

CLX TC

Notes

A large grid area for taking notes, consisting of a 20x30 grid of small squares. The grid is empty and occupies the majority of the page's content area.

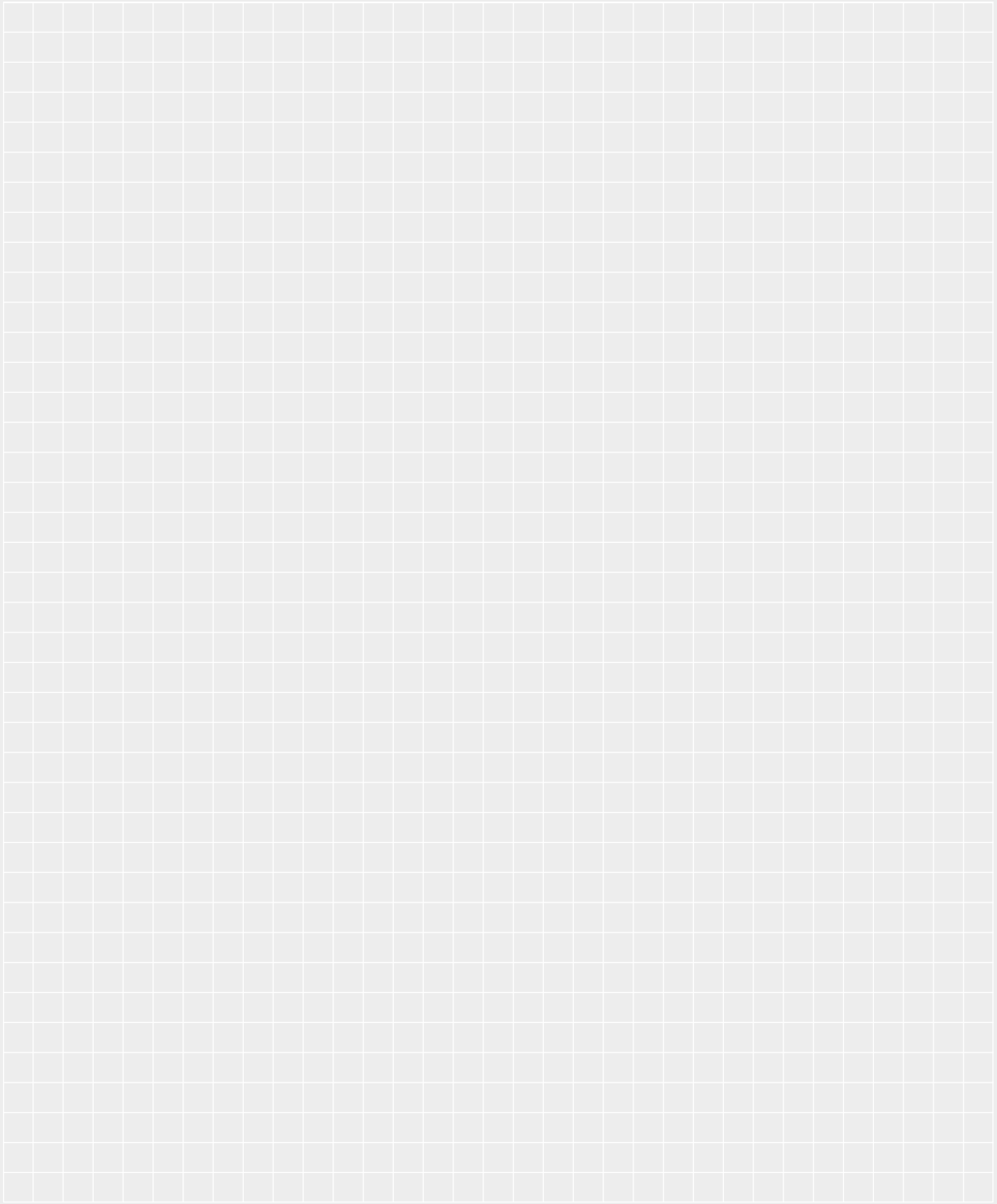
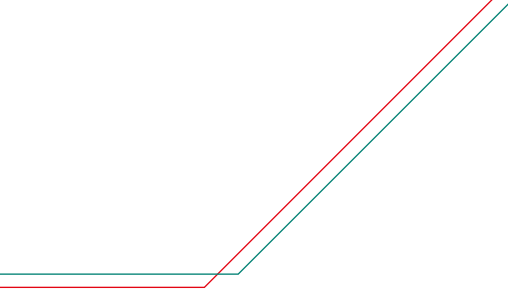



DMG MORI Service – fast and reliable!

“Our service commitment will meet your expectations with the highest quality of service!”

Available for you around the clock:

service-hotline.dmgmori.com 

Top quality at fair prices. **It's a promise!**



Spare Parts: 96 % global availability



Spindle Service with Fair Price Guarantee



Training: Professional training at highest standards



Service Products: Our protective shield for your DMG MORI machine

For further information please contact your local DMG MORI office.