

TECHNICAL SPECIFICATION

EMCOMAT 17 D

EMCOMAT 20 D



CONVENTIONAL TURNING LATHES

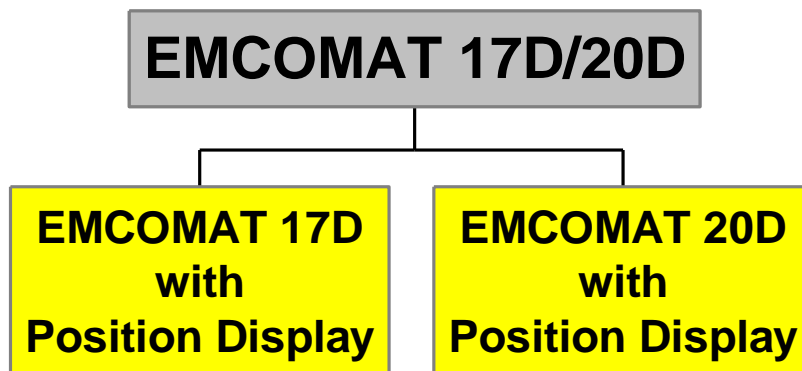

Machines:





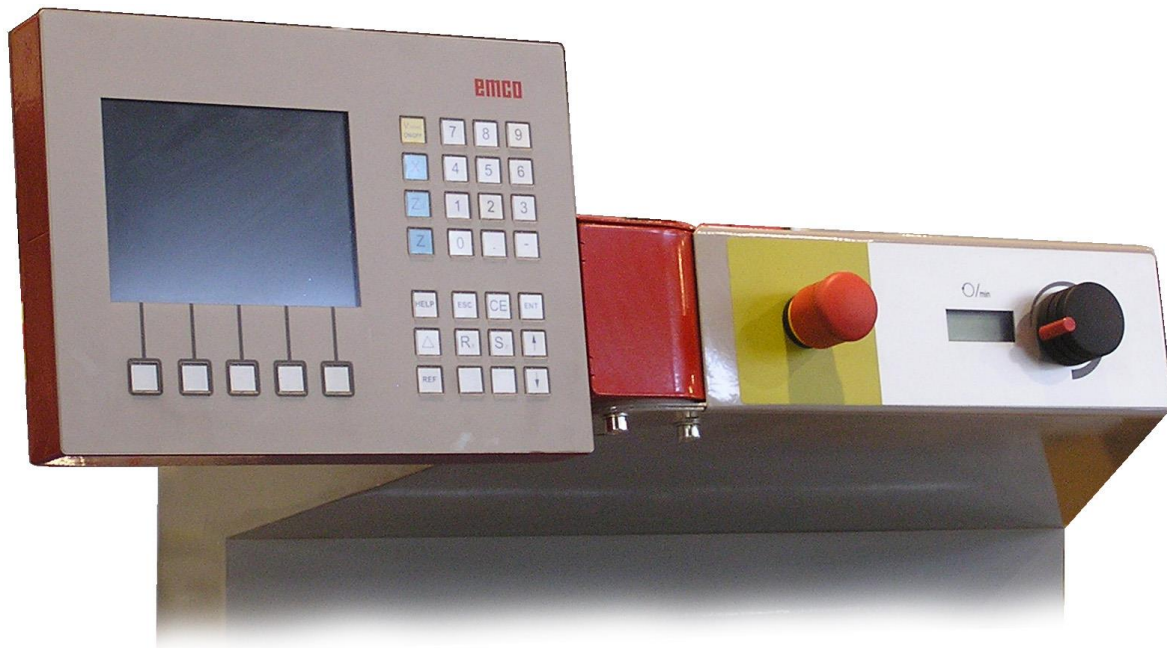

Basic machine	3
Clamping devices	8
Centers	10
Steadies	12
Stops	12
Accessories for tailstock	13
Accessories for machine	13
Measuring tools	15
Toolholders	15
Cutting tools	18
Packing	20
Manual / Prospects	20
TECHNICAL DATA MACHINE EM17S	21
Performance diagram EM17D, EM20D	23
Torque diagram EM17D, EM20D	23

Basic machine	DESCRIPTION	REF.NO.		
	<p><u>EMCOMAT EM 17D</u></p> <p>Universal center lathe, for direct connection DIN55029-S5, toolmaker accuracy DIN 8605, Distance between centers 700 mm, center height 170 mm, with machine base and standard equipment, integrated digital position display, mechanics metric, capacity 5,3 kW (40% ED), 4 spindle speed steps from 40 - 3000 rpm., electr. infinitely variable, incl. chuck guard and spindle cover, incl. chip,- and splashguard, acc. the european safty standard (CE)</p>	<p>6AD4D000</p>		
	<p><u>EMCOMAT EM 20D</u></p> <p>Universal center lathe, for direct connection DIN55029-S5, toolmaker accuracy DIN 8605, Distance between centers 1000 mm, center height 200 mm, with machine base and standard equipment, integrated digital position display, mechanics metric, capacity 5,3 kW (40% ED), 4 spindle speed steps from 40 - 3000 rpm., electr. infinitely variable, incl. chuck guard and spindle cover, incl. chip,- and splashguard, acc. the european safty standard (CE)</p>	<p>6AD4N000</p>		
<p><u>BASIC MACHINE (STANDARD EQUIPMENT)</u></p> <table border="0"> <tr> <td data-bbox="150 1541 676 1845"> <ul style="list-style-type: none"> 1 Longitudinal stop 1 Lathe center, taper 1:22, DIN 7178 1 Lathe center MK3 1 Locking handle 1 Key 1 Grease gun 3 Hexagonal screw M16x60-8.8 DIN933 3 Hexagonal nut M16-8 DIN 934 1 Tool clamp </td> <td data-bbox="767 1435 1294 1845"> <ul style="list-style-type: none"> 1 Wrench A13x17 DIN837 1 Open-ended spanner SW19 1 Open-ended spanner SW22 1 Hexagonal key SW5 1 Hexagonal key SW6 1 Hexagonal key SW8 3 Shear pins 1 E-Box key 1 Operation manual incl. spare parts list 1 Elektrical documentation 1 Test certificate Packing </td> </tr> </table>			<ul style="list-style-type: none"> 1 Longitudinal stop 1 Lathe center, taper 1:22, DIN 7178 1 Lathe center MK3 1 Locking handle 1 Key 1 Grease gun 3 Hexagonal screw M16x60-8.8 DIN933 3 Hexagonal nut M16-8 DIN 934 1 Tool clamp 	<ul style="list-style-type: none"> 1 Wrench A13x17 DIN837 1 Open-ended spanner SW19 1 Open-ended spanner SW22 1 Hexagonal key SW5 1 Hexagonal key SW6 1 Hexagonal key SW8 3 Shear pins 1 E-Box key 1 Operation manual incl. spare parts list 1 Elektrical documentation 1 Test certificate Packing
<ul style="list-style-type: none"> 1 Longitudinal stop 1 Lathe center, taper 1:22, DIN 7178 1 Lathe center MK3 1 Locking handle 1 Key 1 Grease gun 3 Hexagonal screw M16x60-8.8 DIN933 3 Hexagonal nut M16-8 DIN 934 1 Tool clamp 	<ul style="list-style-type: none"> 1 Wrench A13x17 DIN837 1 Open-ended spanner SW19 1 Open-ended spanner SW22 1 Hexagonal key SW5 1 Hexagonal key SW6 1 Hexagonal key SW8 3 Shear pins 1 E-Box key 1 Operation manual incl. spare parts list 1 Elektrical documentation 1 Test certificate Packing 			









Position Display:







- permanent position display of the bed-, cross- and top slide
- the position control of the bed slide is accomplished by a precise measuring toothed rack moving the rotatory position transmitter over a gearwheel
- the position of the cross slide is measured by a glass scale with a 0,001 mm accuracy, in order to adjust the diameter with maximal accuracy
- the position of the top slide is measured by direct drive of the shaft encoder over the adjusting spindle
- functions: constant cutting speed, 99 tools, 99 datums, referencepoint, distance to go Δ , inch/metric, radius-/diameter, separate or sum display for Z and Zo,
- Languages: German, English, Spanish, French, Italian, Dutch, Czech
- Screensize 6,5" color-TFT, 640x480 resolution (VGA)

Clamping devices RÖHM		
	DESCRIPTION	REF.NO.
	<p><u>RÖHM 3-jaw lathe chuck ø 200</u> RÖHM High precision 3-jaw chuck, steel, incl. 1 set out- and inside jaws, for direct mounting acc. to DIN 55029-S5 resp. Camlock ASA 5.9 D1, guarantees a max. permissible run out and plan error 0,05 resp. 0,03 mm permissible speed 4000 rpm., hole through spindle ø 55 mm gripping capacity: outside: 4-200 mm inside: 44-186 mm</p>	6AV7W000R
	<p><u>Soft blank jaws</u> 1 Set soft blank jaws (3 pcs.) for Ref.No. 6AV7W000R</p>	6AV7Z030R
	<p><u>Hardened jaws</u> 3-jaw set outward stepped in lathe chuck Ref.No. 6AV7W000R included !</p>	6AV7Z050R
	<p><u>Hardened jaws</u> 3-jaw set inward stepped in lathe chuck Ref.No. 6AV7W000R included !</p>	6AV7Z060R
	<p><u>RÖHM 3-jaw lathe chuck ø 200</u> RÖHM High precision 3-jaw chuck, steel, incl. 1 hardbase and hard top jaws, for direct mounting acc. to DIN 55029-S5 resp. Camlock ASA 5.9 D1, guarantees a max. permissible run out and plan error 0,05 resp. 0,03 mm hole through spindle ø 55 mm, permissible speed 4000 rpm., gripping capacity: outside: 4-200 mm inside: 50-186 mm</p>	6AU7W000R
	<p><u>Soft top jaws</u> Set soft top jaws (3 pcs.) for Ref.No. 6AU7W000R</p>	6AV7Z120R

	DESCRIPTION	REF.NO.
	<p><u>Hardened base jaw</u> 3-jaw set base jaw in lathe chuck Ref.No. 6AU7W000R included !</p>	<p>6AU7Z100R</p>
	<p><u>Hardened reversible top jaw</u> 3-jaw set reversible top jaw in lathe chuck Ref.No. 6AU7W000R included !</p>	<p>6AU7Z010R</p>
	<p><u>RÖHM 4-jaw lathe chuck ø 200</u> RÖHM High precision 4-jaw chuck, steel, incl. 1 set out-and inside top jaws, for direct mounting acc. to DIN 55029-S5 resp. Camlock ASA 5.9 D1, guarantees a max. permissible run out and plan error 0,05 resp. 0,03 mm, hole through spindle ø 55 mm, permissible speed 4000 rpm., gripping capacity: outside: 4-200 mm; inside: 44-186 mm</p>	<p>6AV7X000R</p>
	<p><u>Soft jaws</u> 4-jaw set unstepped for lathe chuck Ref.No. 6AV7X000R</p>	<p>6AV7Z040R</p>
	<p><u>Hardened jaws</u> 4-jaw set outward stepped in lathe chuck Ref.No. 6AV7X000R included !</p>	<p>6AV7Z070R</p>
	<p><u>Hardened jaws</u> 4-jaw set inward stepped in lathe chuck Ref.No. 6AV7X000R included !</p>	<p>6AV7Z080R</p>

	<p><u>RÖHM Tapered rod chuck DURO -T ø 200</u> RÖHM Tapered rod chuck DURO -T Incl. Hard base jaws and with hardened top jaws, direct mounting acc. to DIN55029-S5 resp. Camlock ASA B5.9 D1 Gr.5 . High clamp force and precision which is twice higher than in DIN 6383, max. permissible speed 4000 u/min, Gripping capacity : outside 7-207 mm, inside 71-214 mm, hole through spindel ø 52 mm</p>	<p>6A212015</p>
	<p><u>Hardened base jaw</u> 3-jaw set base jaw in lathe chuck 6A212015 included !</p>	<p>6A212025</p>
	<p><u>Soft top jaws</u> 1 Set soft top jaws (3 pcs.) for lathe chuck 6A212015</p>	<p>6A212020</p>
	<p><u>RÖHM High precision Face plate ø 250</u> Incl. 4 individually adjustable reversable jaws, for direct mounting acc. to DIN 55029-S5 resp. Camlock ASA B5.9 D1 Gr.5, max. permissible speed 1500 u/min, hole through spindel ø 65 mm</p>	<p>6A222010R only EM20D</p>

Clamping devices BISON	DESCRIPTION	REF.NO.
	<p><u>BISON 3-jaw lathe chuck ø 200</u> BISON High precision 3-jaw chuck, steel, incl. 1 set out- and inside jaws, for direct mounting acc. to DIN 55029-S5 resp. Camlock ASA 5.9 D1, permissible speed 4000 rpm., hole through spindle ø 55 mm</p>	<p>6AV7W000B</p>
	<p><u>Soft blank jaws</u> 1 Set soft blank jaws (3 pcs.) for Ref.No. 6AV7W000B</p>	<p>6AV7Z030B</p>
	<p><u>Hardened jaws</u> 3-jaw set outward stepped in lathe chuck Ref.No. 6AV7W000B included !</p>	<p>6AV7Z050B</p>
	<p><u>Hardened jaws</u> 3-jaw set inward stepped in lathe chuck Ref.No. 6AV7W000B included !</p>	<p>6AV7Z060B</p>
	<p><u>BISON 3-jaw lathe chuck ø 200</u> BISON High precision 3-jaw chuck, steel, incl. 1 hardbase and hard top jaws, for direct mounting acc. to DIN 55029-S5 resp. Camlock ASA 5.9 D1, hole through spindle ø 55 mm, permissible speed 4000 rpm.,</p>	<p>6AU7W000B</p>
	<p><u>Soft top jaws</u> Set soft top jaws (3 pcs.) for Ref.No. 6AU7W000B</p>	<p>6AV7Z120B</p>

	DESCRIPTION	REF.NO.
	<p><u>Hardened base jaw</u> 3-jaw set base jaw in lathe chuck Ref.No. 6AU7W000B included !</p>	<p>6AU7Z100B</p>
	<p><u>Hardened reversible top jaw</u> 3-jaw set reversible top jaw in lathe chuck Ref.No. 6AU7W000B included !</p>	<p>6AU7Z010B</p>
	<p><u>BISON 4-jaw lathe chuck ø 200</u> BISON High precision 4-jaw chuck, steel, incl. 1 set out-and inside top jaws, for direct mounting acc. to DIN 55029-S5 resp. Camlock ASA 5.9 D1, hole through spindle ø 55 mm, permissible speed 4000 rpm.,</p>	<p>6AV7X000B</p>
	<p><u>Soft jaws</u> 4-jaw set unstepped for lathe chuck Ref.No. 6AV7X000B</p>	<p>6AV7Z040B</p>
	<p><u>Hardened jaws</u> 4-jaw set outward stepped in lathe chuck Ref.No. 6AV7X000B included !</p>	<p>6AV7Z070B</p>
	<p><u>Hardened jaws</u> 4-jaw set inward stepped in lathe chuck Ref.No. 6AV7X000B included !</p>	<p>6AV7Z080B</p>

	<p><u>BISON Tapered rod chuck ø 200</u> BISON 3 jaw tapered rod chuck made of steel incl. hard base jaws and with hardened top jaws, direct mounting acc. to DIN55029-S5 rsp. Camlock ASA B5.9 D1 Gr.5 . High clamp force and precision which is twice higher than in DIN 6383, max. permissible speed 4600 rpm, hole through spindel ø 51 mm</p>	<p>6A212015B</p>
	<p><u>Hardened base jaw</u> 3-jaw set base jaw in lathe chuck 6A212015B included</p>	<p>6A212025B</p>
	<p><u>Soft top jaws</u> 1 Set soft top jaws (3 pcs.) for lathe chuck 6A212015B</p>	<p>6A212020B</p>
	<p><u>BISON Face plate ø 200</u> Incl. 4 individually adjustable reversable jaws, for direct mounting acc. to DIN 55029-S5 rsp. Camlock ASA B5.9 D1 Gr.5, max. permissible speed 1800 u/min, hole through spindel ø 50 mm</p>	<p>6AP7X000B</p>

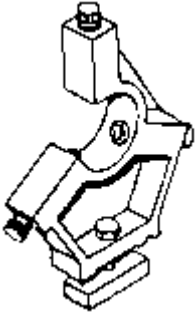
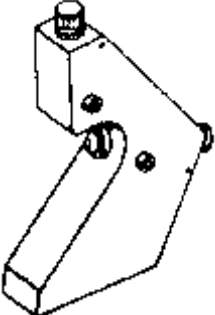

	DESCRIPTION	REF.NO.
	<p><u>Clamping plate ø 280</u> for unsymmetrical workpieces Clamping device: clamping shoes or direct fix with a screw for direct mounting acc. to DIN 55029-S5 resp. Camlock ASA B5.9 Gr.5</p>	<p>6AD3Z130</p>
	<p><u>Rapid action collet chuck</u> with hand lever and end-switch supervision for direct mounting acc. to DIN 55029-S5 resp. Camlock ASA B5.9 Gr.5 Concentricity 0,04 mm Spindle bore in tension tube ø 43mm</p> <p>Use with collets 173E, 2-42 mm</p>	<p>6AD4Z080</p> <p>Factory fitted only (Class 2) !</p>
	<p><u>Collets 173E</u> suitable to 6AD4Z080 Clamping capacity 2 - 42 mm Order example: collet ø 20 ==>> collet ø 33 ==>></p>	<p>6A575200 6A575330</p>
	<p><u>FN collet chuck 173E (F48) DIN6343</u> Clamping capacity 3-42 mm Diameter 160 mm Clamping by key on the chuckbody</p>	<p>6A212460</p>

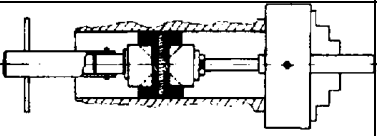
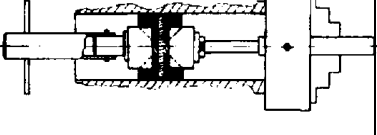
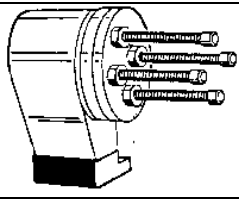
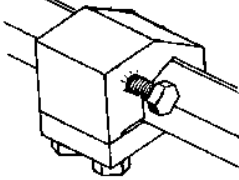
Steadies		
	DESCRIPTION	REF.NO.
	<p><u>Fixed steady</u> with replaceable bronze and roller inserts workpiece \varnothing 6-100 mm</p> <p>center height 170 mm, EM 17D center height 200 mm, EM 20D</p>	<p>6AD3Z240 6AD3Z340</p>
	<p><u>Follow rest</u> with replaceable bronze and roller inserts workpiece \varnothing 6-100 mm</p> <p>center height 170 mm, EM 17D center height 200 mm, EM 20D</p>	<p>6AD3Z230 6AD3Z330</p>

Stops		
	DESCRIPTION	REF.NO.
	<p><u>Hollow spindle stop</u> (47-57mm) incl. key.</p>	6A212370
	<p><u>Hollow spindle stop for Rapid action collet chuck (6AD4Z080)</u> (39-47mm) incl. key.</p>	6A212520
	<p><u>Turret stop</u> for longitudinal turning. 4 stops</p>	6AD3Z020
	<p><u>Micrometer stop</u></p>	6AD3Z030

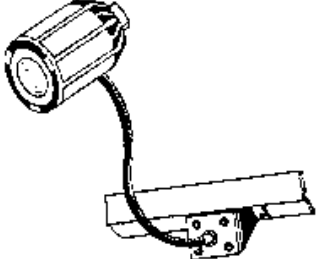
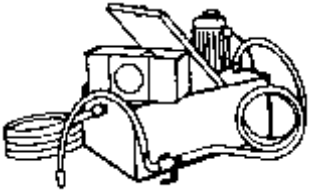
Accessories for tailstock		
	DESCRIPTION	REF.NO.
	<u>Life center MT3</u> max. concentr. error 0,008mm	6A565030R
	<u>Center drill top for life center</u> to use with 6A565030R	6A212060R
	<u>Rapid clamping drill chuck, type 136 supra</u> clamps from 3-16 mm, mount B18 Morse taper arbor (6A565055) necessary	6A250045
	<u>Morse taper arbor MT3/B18</u> for drill chuck 6A250045	6A565055

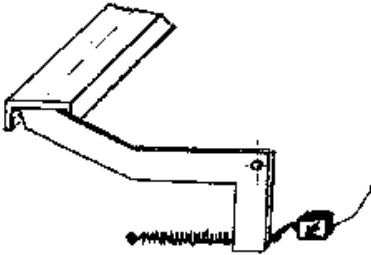
Accessories for machine		
	DESCRIPTION	REF.NO.
	<u>LED Machinelamp 24 V 3 W</u>	6AD4Z310
	<u>Integrated cooling facility</u> replaceable tank, tank 20 l, conveying capacity 30 l/min,	6AD4Z460

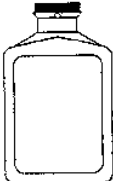
	DESCRIPTION	REF.NO.
	<p><u>Foot-Operated Spindle-STOP (Foot Brake)</u></p> <p>footswitch for EM 17D footswitch for EM 20D</p>	<p>6AD3Z530 6AD3Z540</p>
	<p><u>Tool cupboard (drawer)</u></p>	<p>6AD4Z800</p>
	<p><u>chip guard door (moveable) for EM 17D</u></p>	<p>6AD4Z010</p>
	<p><u>chip guard door (moveable) for EM 20D</u></p>	<p>6AD4Z020</p>
	<p><u>Levelling element</u></p> <p>3 pieces necessary</p>	<p>6AF3Z150</p>
	<p><u>Special painting</u></p> <p>prices and colours on application !</p>	<p>Factory fitted only (Class 3) !</p>
	<p><u>Gear Oil for Headstock and Gearbox</u></p> <p>1 Litre Mobil DTE 25</p>	<p>6A751000</p>

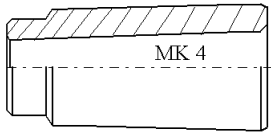
	DESCRIPTION	REF.NO.
	<p><u>Gear quadrant for metric machine</u></p> <p>to cut following additional threads: 32 inch 4-56 Gg/inch, 28 module threads 0.2-3.5, 32 diametrical pitches 8-112 Change gears: 30, 40, 50, 60, 63, 65, 70, 75, 80, 95, 100, 110, 120, 127</p>	6AD3Z200
	<p><u>Reduction sleeve</u></p> <p>spindle inside taper to MT 4</p>	6AD3Z050

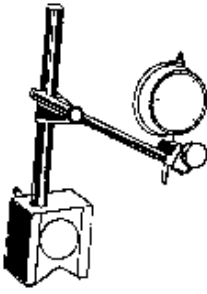
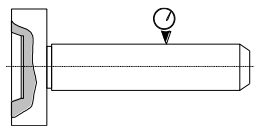
Measuring tools		
	DESCRIPTION	REF.NO.
	<p><u>Dial gauge with holder</u></p> <p>shock protection, fine setting of pointer, scale increments 0,01 mm, measuring range 10 mm, magnetic foot with prism, total height 235mm,</p>	6A565065
	<p><u>Test mandrel</u></p> <p>Main spindle (packed in wooden box) Tailstock MT3 (packed in wooden box)</p>	6AD4Z610 6AD4Z620

Toolholders		
	DESCRIPTION	REF.NO.
	<p><u>Quick-change toolpost – SET B</u></p> <p>comprising basic holder, 4 pcs. standard BD 25/20/120 and 1 pcs. prism tool post BH 28/32/130 suitable for toolset with carbide-tipped indexable inserts</p>	6A212230

	DESCRIPTION	REF.NO.
	<p><u>Quickchangetoolpost Size B</u></p>	<p>6A212160</p>
	<p><u>Standard toolpost</u> Standard toolholder BD25/20/120 for cross section 20 x 20 mm, for Ref. No. 6A212160 and 6A212230</p>	<p>6A212170</p>
	<p><u>Prism toolpost</u> Prism toolpost for boring bars BH28/32/130 for Ref.No. 6A212160 and 6A212230</p>	<p>6A212180</p>
	<p><u>Parting off holder</u> Parting-off holder BT-K with blade for Ref.No. 6A212160 and 6A212230</p> <p><u>Spare parting-off blade</u> Replacement-blade A1/2A-F width 4 mm, height 16 mm</p>	<p>6A212190</p> <p>6A212200</p>
	<p><u>Bush holder</u> Bush holder BJ 28/40/120 Diameter 40 mm, for Ref. No. 6A212160 and 6A212230</p> <p><u>Bush with morse taper MT3 BL 3/40</u></p>	<p>6A212210</p> <p>6A222160</p>
	<p><u>Lever device for outside threads</u> for Ref.No. 6A212160 and 6A212230</p>	<p>6A212220</p>

	DESCRIPTION	REF.NO.
	<p><u>Set 4-way turret PARAT RD1</u></p> <p>Set including 4-way turret RD1, 4 pcs. change holder WD 1/20 and 1 pcs. change holder WDPL 1/12</p> <p>Attention: mounting kid RD1/ EM17 necessary!</p> <p>Attention: mounting kid RD1/ EM20 necessary!</p>	<p>6A223671</p> <p>6A223672</p> <p>6A223673</p>
	<p><u>Toolholder</u></p> <p>Toolholder WD 1/20 for RD 1 (standard toolholder)</p>	<p>6A223700</p>
	<p><u>Toolholder</u></p> <p>Toolholder WB 1/30 for RD 1 (boring bar holder diam. 30)</p>	<p>6A223680</p>
	<p><u>Toolholder</u></p> <p>Toolholder WDPL 1/12 for RD 1 (prism toolholder)</p>	<p>6A223690</p>
	<p><u>Withdrawal sleeve</u></p> <p>Withdrawal sleeve CM 2/30 for WB 1/30 for RD1</p>	<p>6A223710</p>

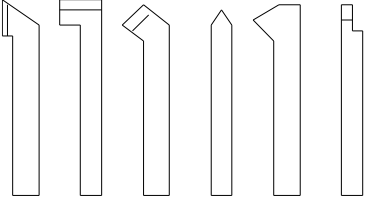
Cutting tools	DESCRIPTION	REF.NO.
	<p><u>6 HSS turning tools</u></p> <p>cross section 20x15, comprising: right-hand toolholder outside, right-hand toolholder inside, 45° roughing tool, Parting off tool, 60° outside thread toolholder, 60° inside thread toolholder</p>	<p>6A211550</p>
	<p><u>Tool package with 5 toolholders (Ceratzit)</u></p> <p>Comprising: right hand roughing toolholder, right hand toolholder, boring bar ø 20 mm, facing toolholder, basic toolholder for cutting off (incl. module for basic toolholder)</p> <ul style="list-style-type: none"> • 5 pieces carbide tips Sr127 GX16-2EE2.50N0.20 • 5 pieces carbide tips Gm40 CCMT09T304EN • 5 pieces carbide tips Gm40 DCMT070204EN • 5 pieces carbide tips Gm40 SCMT09T304EN • 5 pieces carbide tips Gm35 DCMT11T304EN 	<p>6A212240</p>

	DESCRIPTION	REF.NO.
	<u>Right hand roughing toolholder</u> SCLCR2020K09	6A212250
	<u>Right hand toolholder</u> SDJCR2020K11	6A212260
	<u>Facing toolholder</u> SSSCR2020K09	6A212270
	<u>Basic toolholder for cutting off tool</u> MSS-E20R002020J (must be orderd with 6A212290) <u>Module for basic toolholder</u> MSS-E20R12GX16-1 (must be orderd with 6A212280)	6A212280 6A212290
	<u>Boring bar ø 20 mm</u> A20QSDUCR07	6A212300
	<ul style="list-style-type: none"> • <u>5 pieces carbide tips Sr127</u> GX16-2EE2.50N0.20 suitable to 6A212290 (6A212280) • <u>10 pieces carbide tips Gm40</u> CCMT09T304EN suitable to 6A212250 • <u>10 pieces carbide tips Gm40</u> SCMT09T304EN suitable to 6A212300 • <u>10 pieces carbide tips Gm35</u> DCMT070204EN suitable to 6A212270 • <u>10 pieces carbide tips Gm40</u> DCMT11T304EN suitable to 6A212260 	6A212310 6A212320 6A212330 6A271055 6A212420
	<u>Outside thread tool 60°</u> (for ref.no.6A212220)	6A212360

Packing		
	DESCRIPTION	REF.NO.
	<p><u>Climate packing EMCOMAT 17D</u></p> <p>Consisting of: pallet, dehumidifier, aluminium-cover and miscellaneous</p>	6AD4A998000Z
	<p><u>Wooden box EMCOMAT 17D</u></p> <p>Additional protection for critical transportation. (Attention: additional to standard or climate packing)</p>	6AD4A997000Z
	<p><u>Climate packing EMCOMAT 20D</u></p> <p>Consisting of: pallet, dehumidifier, aluminium-cover and miscellaneous</p>	6AD4N998000Z
	<p><u>Wooden box EMCOMAT 20D</u></p> <p>Additional protection for critical transportation. (Attention: additional to standard or climate packing)</p>	6AD4N997000Z

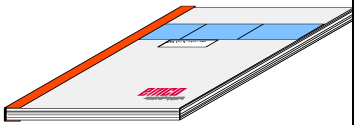
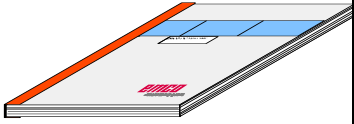
Manual / Prospects		
	DESCRIPTION	REF.NO.
	<p><u>Operation manual</u></p> <p>Operation manual and service parts list EM 17D/20D</p>	<p>6ADE 2205 6AEN 2205 6AFR 2205 6ATA 2205 6ASP 2205 6AHL 2205</p>
	<p><u>Brochures EMCOMAT-Conventional Turning</u></p> <p>Brochure NEW Conventional lathes</p>	<p>6ADE 3381 6AEN 3381 6AFR 3381 6ATA 3381</p>

TECHNICAL DATA MACHINE EM17S

		EM 17D	EM 20D
Working range			
distance between centers	[mm]	700	1000
center height	[mm]	170	200
swing over bed	[mm]	Ø 340	Ø 400
swing over cross slide	[mm]	Ø 190	Ø 250
width of lathe bed	[mm]	260	260
travel longitudinal slide	[mm]	600	900
travel cross slide	[mm]	220	220
travel top slide	[mm]	110	110
cross slide (length over traverse)	[mm]	410	410
cross slide (width over traverse)	[mm]	150	150
guiding length of bed slide	[mm]	380	380
turning tool cross section	[mm]	20x20	20x20
distance top slide - turning center	[mm]	34	40
Swivel-range of top slide	[°]	60/120	60/120
Main spindle			
spindle nose acc. DIN 55 029 (Camlock)		S 5	S 5
hole through spindle	[mm]	Ø 50	Ø 50
inside taper acc. DIN 7178		1:22	1:22
spindle diameter in front bearing	[mm]	Ø 70	Ø 70
chuck diameter (maximum)	[mm]	Ø 200	Ø 200
face plate diameter (maximum)	[mm]	Ø 200	Ø 260
spindle speeds	[rpm]	40-3000	40-3000
spindle speed regulation		stepless	stepless
mechanical gear steps		4	4
Speeds 17S: 55, 95, 160, 280, 470, 800, 1320, 2350	[rpm]		
Drive motor			
IEC motor, three phase motor with brake			
motor speed	[rpm]		
capacity at 40% ED	[kW]	5,3	5,3
max. torque at main spindle	[Nm]	640	640
Feeds			
20 (28) longitudinal feed rates Z	[mm/rev]	0,045-0,787	0,045-0,787
20 (28) transversal feed rates X	[mm/rev]	0,023-0,406	0,023-0,406
Threads			
20 (28) threads in basic version	[mm]	0,4 – 7,0	0,4 – 7,0
32 inch threads (with option change gear set D3Z200)	[tpi]	56 – 4	56 – 4
28 module threads (with option change gear set D3Z200)		0,2 – 3,5	0,2 – 3,5
32 diam. Pitches (with option change gear set D3Z200)		112 – 8	112 – 8

Tailstock		EM 17D	EM 20D
sleeve diameter	[mm]	∅ 50	∅ 50
Internal taper of tailstock sleeve	[MT]	3	3
stroke of centre sleeve	[mm]	120	120
adjustment at the side	[mm]	± 13	± 13
Graduated Collar Division of Handwheels			
longitudinal side Z	[mm]	0,2	0,2
cross slide X	[mm]	to 0,05	to 0,05
top slide Zo	[mm]	0,025	0,025
Tailstock	[mm]	0,1	0,1
Allowable Workpiece Weight			
Flying	[kg]	50	50
with tailstock	[kg]	150	150
Electrical Connection			
voltage supply 3 ~ /PE	[V]	400	400
	[V]		
	[V]		
voltage tolerance	[%]	+5/-10	+5/-10
Frequency	[Hz]	50/60	50/60
electr. Connection	[kVA]	5,0	5,0
main fuse	[A-inert]	16	16
temperature (humidity 20-75%)	[degree]	10 – 35	10 – 35
Dimensions			
length	[mm]	1650	1950
Width	[mm]	1060	1060
Height	[mm]	1635	1635
operating height (spindle)	[mm]	1103	1103
Weight	[kg]	755	865
Digital read out			
Integrated in 3 axis – changeable		[mm/inch]	[mm/inch]
smallest display unit X – axis (cross slide)	[mm]	0,001	0,001
smallest display unit Zo – axis (top slide)	[mm]	0,005	0,005
smallest display unit Z – axis (longitudinal slide)	[mm]	0,01	0,01
Painting			
red		RAL 3020	RAL 3020
light-grey		RAL 7035	RAL 7035
graphite-grey		RAL 7024	RAL 7024
Sound Pressure Gage			
sound pressure value by following conditions: <ul style="list-style-type: none"> method of measurement: enveloping surface methoe acc. to DIN 45 635 measuring point: 1m distance and 1,6m over the floor working condition: highest spindle speed in idle running 	[dB (A)]	79	79

Performance diagram EM 17D, EM 20D

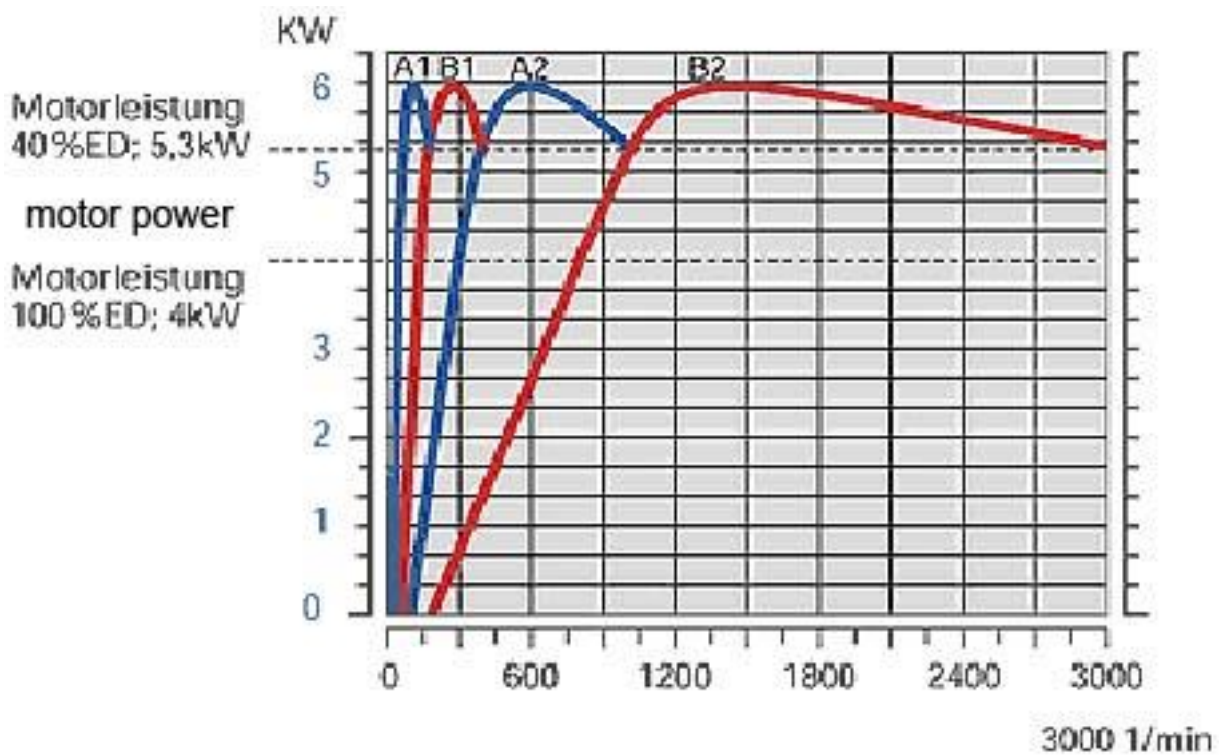

Torque diagram EM 17D, EM 20D

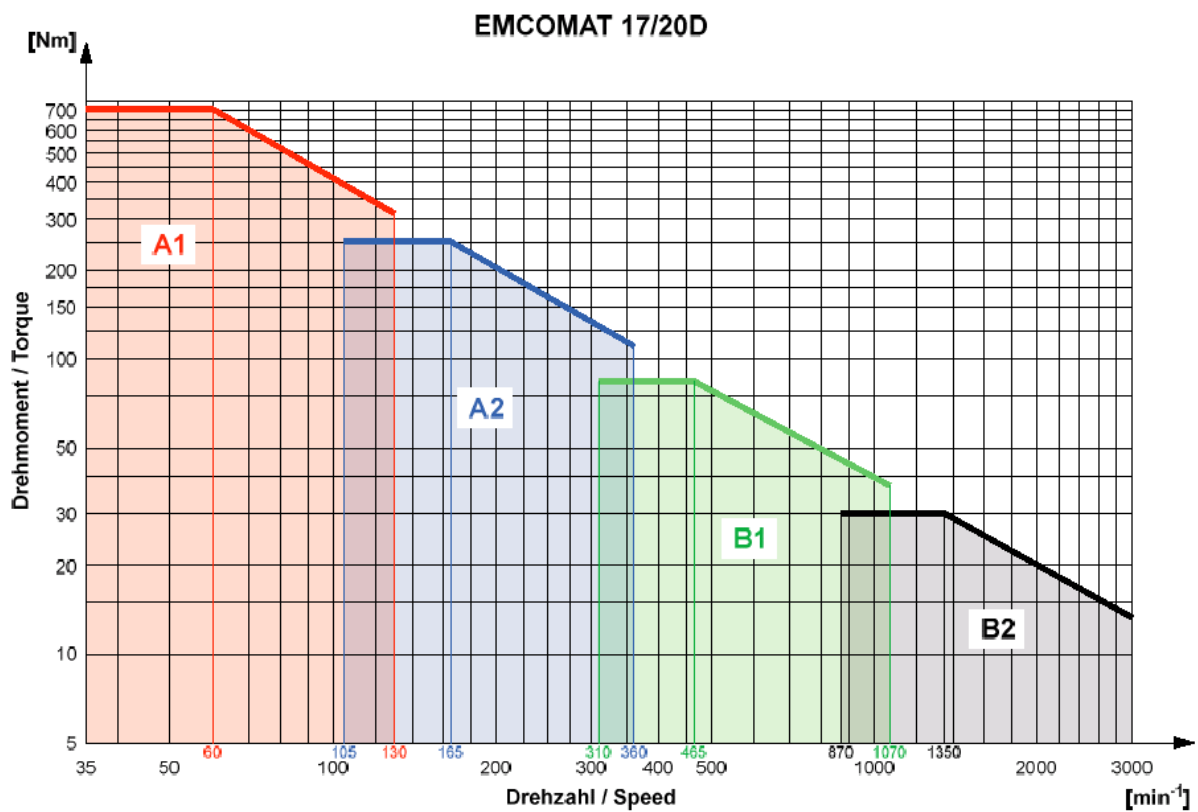

Technical Main Features of the Machine Elements EM 17D/20D

The Concept:

Engineered to meet rugged professional requirements, the EMCOMAT 17D/20D responds with all those fine technical features that distinguish a modern industrial leadscrew / feedshaft lathe.

The Users:

The EMCOMAT 17D/20D will prove a reliable partner in all cases calling for the production of complex shapes, spares, dies or small-run production series. It will prove just as indispensable to: Precision mechanics, Repair workshops, Die makers, Optical workshops, Electrical workshops, Automobile workshops, Airplane and helicopter service enterprises, Technical and scientific laboratories, Schools and apprentices' training shops, Motor tuning, Formula 1 and motorcycle racing service.

Headstock

- compact, torsion free grey cast housing
- extremely rigid main spindle with taper roller bearing
- short taper with enlarged Camlock-fixing
- 3 - shaft sliding gear drive with 8 or 4 lever positions, low running noise and low circumferential backlash are guaranteed
- hardened and ground gearwheels
- lubrication through oil pan
- gear shifting through 2 operating levers
- integrated feed reverse gearing
- a total cover of the headstock motor, change gear quadrant and feed drive
- round forms ensure ergonomic favourable operating facility

Feed gear

- improved operating facility by mounting of the levers and enlarging the operating travel
- slide drive through lead screw and feed shaft
- lead screw can be declutched

Apron

- ergonomically improved position of the lever of longitudinal and traversal feed
- mounting of a control panel on the right hand side with left-right switch and emergency switch off, or additionally with integrated position display
- integrated overload clutch protect the feed drive

Slide

- very long cross slide, possible for 2 tools or taper turning attachment
- exceedingly long longitudinal guidance improves cross stability
- central lubrication facility

Tailstock

- high-grade cast iron construction
- enlarged center sleeve travel and diameter
- Morse taper with locking piston for flap drills

Machine stand

- Steel plate construction
- preparation for integrated coolant equipment
- removable chip tray
- inclined drip plate for better cleaning
- splash guard
- 3-point support system for machine stand

Bed

- rugged iron-cast construction with diagonal ribbing
- large width of bed with good chip clearance
- hardened (HB30 4000 ± 1000N/mm²), ground V-guides
- excellent geometric precision through maximal height and width
- 3-point support system to machine stand

Lead screw and feed shaft cover

- meets with highest security requirements
- stainless steel material facilitates cleaning

Infinitely variable main drive 17D/20D

- feed control of the three phase motor by an electronic frequency converter
- Additionally, the torque is chosen by a 4-step gearing, in order to work with the most favourable efficiency of the motor at any time
- A permanent display of the actual main spindle speed is mounted at the control panel on the right-hand-side of the apron favourably positioned, as well as a turning knob for speed control and the switch for left-right run.

Electrical Data:

- Fuse for control power circuit and machine lamp
- Built-in thermal-overload relay for main motor, motor of vertical unit and coolant equipment
- Safety guard with micro switch to protect unintentional opening of gear-housing cover
- Electrical cabinet with cable inlet and terminal strip for electrical connection of coolant equipment and machine lamp without power supply cable
- Main motor and electrical cabinet protected according to IP54

Electric:

The electrical equipment complies with the latest technical guidelines in accordance with EN 60204, EN 292, IEC 204, VDE 0113 and ÖVE EN 13.

All accessories are integrated into the safety concept and can be connected to the assigned terminal strip, provided for the purpose.

Safety:

The EMCOMAT 17D/20D is equipped with a completely new safety concept according to the European safety standards (CE)

Mechanical safety features:

- Feedshaft with slip clutch protects the machine against overload and permits precision turning to dead-stop length
- Feed lever lock prevents unintentional switching from longitudinal- to cross feed and vice versa
- Feed lever and halt-nut lever interlocked. This prevents simultaneous engagement of the feedshaft and leadscrew
- Leadscrew is fitted with claw clutch and is only engaged at thread cutting.
- Bed slide fitted with gibs to prevent shearing point between bed slide and tailstock
- Crush point between cross slide and cross spindle defused by gibs
- Cover for leadscrew
- Splash guard
- Chuck guard cover with chuck guard interlock

Electrical safety features:

- Lockable main switch
- Electric chuck guard with limit switch
- Emergency-Off push-button
- Isolating transformer for control voltage 24V
- Power restoral lock in case of under voltage or safety feature respond
- Thermal overload protector integrated in main drive motor
- Complete electrical circuit features fuse protected

Quality:

Highest quality standards acc. to ISO9000:2001 are attained by applying advanced production- and testing methods.

Service:

EMCO operates a dense service network, warranting assistance at all times should the occasion arise.